

TUNING/JETTING COMPONENTS

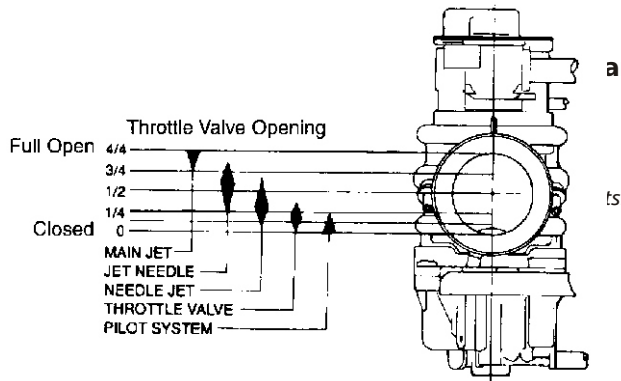

Parts - In Relation to the Throttle Valve Opening

MAIN JETS

Large Hex

TCI PART# 4/042 - (Jet Size)

Fits VM and TM Series

Jets are pre-packaged in bags of 4 but price is based on single jet. Please order Large Hex Main Jets in multiples of 4.

- 6 mm hex width, 5 mm thread diameter

Available Jet Sizes:

- 50 - 245 (increments of 5)
- 250 - 500 (increments of 10)
- 500 - 640 (increments of 20)
- 650, 660, 680, 700, 710, 720

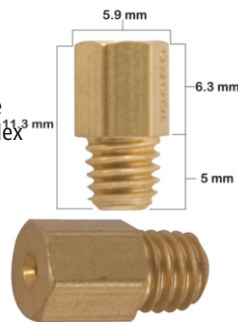

Small Hex

TCI PART#M10/14 - (Jet Size)

- Length 8 mm, 6 mm O.D.

Available Jet Sizes:

- 40 - 200 (increments of 5)

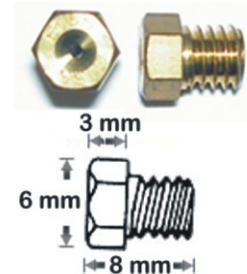

Large Round

TCI PART#N100/604 - Jet Size

Fits RS and HS Series

- Length 9 mm, 8 mm O.D.

Available Jet Sizes:

- 50 - 200 (increments of 2.5)
- 205 - 210 (increments of 5)
- 225 - 240 (increments of 10)

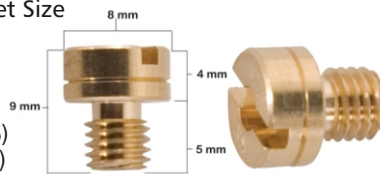

Small Round

TCI PART#N102.221 - Jet Size

Fits SBN Series

- Length 9 mm, 6 mm O.D.

Available Jet Sizes:

- 30 - 250 (increments of 2.5)



Large Thread

TCI PART#VM11/22 - Jet Size

- Length 8 mm, 10.5 mm O.D.

- Available Jet Sizes:

- 50 - 180 (increments of 5)

- [Special Order](#)

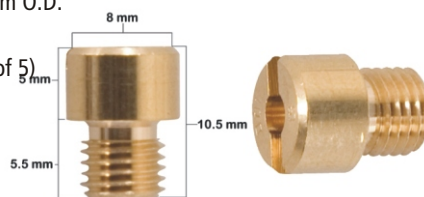

Press - In

TCI PART#N208.099 - Jet Size

Press in OEM Applications

- Length 9 mm, 6 mm O.D.

Available Jet Sizes:

- 115 thru 150 (increments of 5)

