

HSR Series Carbs

The number one performance carburetor for all Harley Davidson and American big twins now slips onto any late model Harley-Davidson using the original throttle cables. Mikuni's Twin Cam, Big Twin and Sportster / Buell Easy Kits even use Harley's existing manifold, choke cable and air filter.

Keep your Harley's stock factory look and fit with better throttle response, improved acceleration, increased power and torque. Delivers peak performance from idle to Wide Open Throttle

DESCRIPTION	FINISH	PART #
HSR 42 mm Carburetor	Standard	TM42-6
HSR 42 mm Carburetor	Polished	TM42-6PK
HSR 45 mm Carburetor	Standard	TM45-2
HSR 45 mm Carburetor	Polished	TM45-2PK

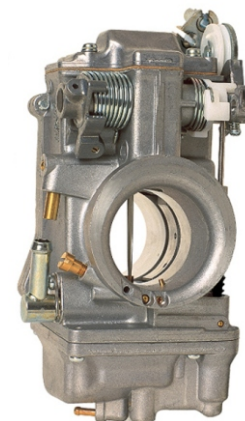

HSR Accessories

Crankcase Head-Breather Kits

For the installation of HSR Carburetor Kits using the K&N high flow filter on Big Twins and Twin Cams.

DESCRIPTION	PART #
To mount HSR42/45 carb and filter to Evo Big Twins	KHS-020
To mount HSR42/45 carb and filter to Twin Cam engine	KHS-030

Jetting Parts

DESCRIPTION	SIZES	PART #
Pilot Jet	15 to 50	VM28/486-(size)
Main Jet	140 to 240	N100.604-(size)
HSR42 Jet Needles	95, 96, 97 & 98	J8-8DDY01-(size)
HSR45 Jet Needles	95, 96, 97 & 98	J8-8CFY02
Accelerator Pump Nozzle	50, 60 & 70 (std. is 70)	TM42/11-(size)
Accelerator Pump O-Ring		N124.063
Jet Assortment Kit for HSR (44 piece assortment w/box)		KHS-025

Throttle Cables - early HSR 42/45

HSR42/45 Carb kits from 1994-99 required Mikuni throttle cables. HSR42 carbs made after May '99, and HSR45 made after March '00 use stock Harley-Davidson cables.

Open Throttle Cable 1970-1995 (38" screw-in type)	HS42/028-A
Close Idle Cable 1970-1995 (38" screw-in type)	HS42/029-A
Open Throttle Cable 1970-1995 (47" screw-in type)	KHS/039
Close Idle Cable 1970-1995 (47" screw-in type)	KHS/040
Open Throttle Cable 1996 - present (38" push-in type)	KHS/043
Close Idle Cable 1996 - present (38" push-in type)	KHS/044
Open Throttle Cable 1996 - present (47" push-in type)	KHS/041
Close Idle Cable 1996 - present (47" push-in type)	KHS/042

Optional and Replacement Parts

Short Idle Screw Adjuster (uses standard spring)	990-605-065
Long Idle Cable Adjuster (spring not included)	TM42/32
Choke Cable (enrichener)	990-662-002
Air Box Adapter (standard finish)	HS42/001
Adapter Screws	HS42/002
O-Ring Seal (for airbox adapter)	HS42/003
Rubber Flange Adapter (early 42 mm black with stainless steel clamp)	HS42/018-42
Rubber Flange Adapter (42 mm black with stainless steel clamp)	HS42/062-42
Air Filter (K&N) 2.5" washable (std. In kits)	HS42/012
Chrome Carb Top (42/45 mm)	KHS-028
Chrome Carb Top (42/45 mm) with Mikuni Logo	KHS-029



Mikuni HSR Series Carburetor Kits

- HSR Carbs use stock Harley-Davidson throttle cables
- very Mikuni Carburetor Kit is an easy bolt-on application.
- Each HSR carburetor in the kit comes pre-jetted and ready to run.

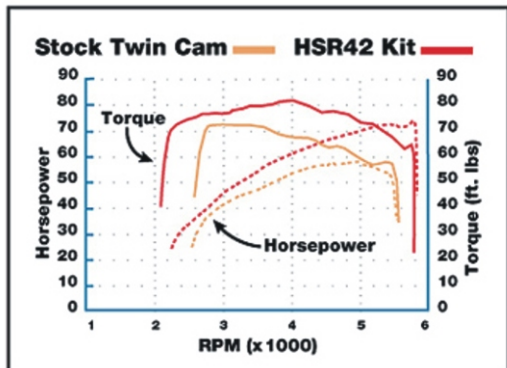

Bolt On a 25% Power and Torque Increase!

Mikuni's Easy Kit dramatically improves the performance of Harley-Davidson's Twin Cam engine and delivers unmatched throttle response and acceleration!

Easy Kits for Sportsters, Big Twin and Twin Cam Models (42 mm)

These kits are designed to work with your original Harley-Davidson intake manifold, choke cable, air cleaner and throttle cables. You can run other high performance air filters designed for the CV type carb by using the special adapter included in the kit.

APPLICATION	TCI PART #
1990 to 1999 1340 Big Twin Evo with stock CV type manifold	HSR42-7-K
1990 to 1999 Big Twin Evo, 1999 to present Twin Cam	HSR42-18-K
<i>Twin Cam and Evo engines require the use of an aftermarket air cleaner. Will not work with stock air box.</i>	
1994 to 2004 Sportster 1200	HSR42-10-K
<i>Requires the use of the stock oval cover and a Screamin' Eagle high flow replacement filter.</i>	
1994 to 2006 Sportster 1200, Buell models	HSR42-11-K
<i>Must be used with an aftermarket performance air filter.</i>	

Total Kits for Big Twin Evolutions and Twin Cam Models (42/45 mm)

These kits are complete with everything needed for a total installation. Kits include an HSR 42 mm or 45 mm carburetor, new performance manifold, rubber flange, high flow air filter, chrome cover, chrome breather kit and mounting hardware. Stock cables for 1990 and later models can be used with this kit.

APPLICATION	TCI PART #
1984 to 1999 1340 Big Twin Evo 42 mm	HSR42-8-K
<i>1984 to 1989 models require cables from a similar 1990 to 1995 model</i>	
1999 to present Twin 88/95 42 mm	HSR42-19-K
<i>Use stock throttle cables</i>	
1984 to 1999 - 1340 Big Twin Evo 45 mm	HSR45-2-K
1984 to 1999 - 1340 Big Twin Evo 45 mm	HSR45-3-KR
<i>same as HSR45-2-K without intake manifold</i>	
1999 to present Twin 88/95 45 mm	HSR45-4-K



Race Kit 48 mm for Big Motors

Designed for the serious race engine builder and extreme street motor enthusiast looking for more power. Recommended for 120 ci engines or bigger with high flow heads and cams. Kits include a 48 mm smoothbore carburetor, rubber mounting flange (78 mm bolt hole centers), choke cable, and 4 main jets.

DESCRIPTION	TCI PART #
HSR Standard Race Kit 48 mm	HSR48-2.so
Standard cast alloy body, cadmium fittings	
HSR48 Polished Race Kit 48 mm	HSR48-2P.so
Hand polished cast alloy body, chrome fittings	



HSR42/45/48 CARBURETOR EXPLODED VIEW

HSR42/45/48

• CHOKE CABLE ASSEMBLY
990-662-002

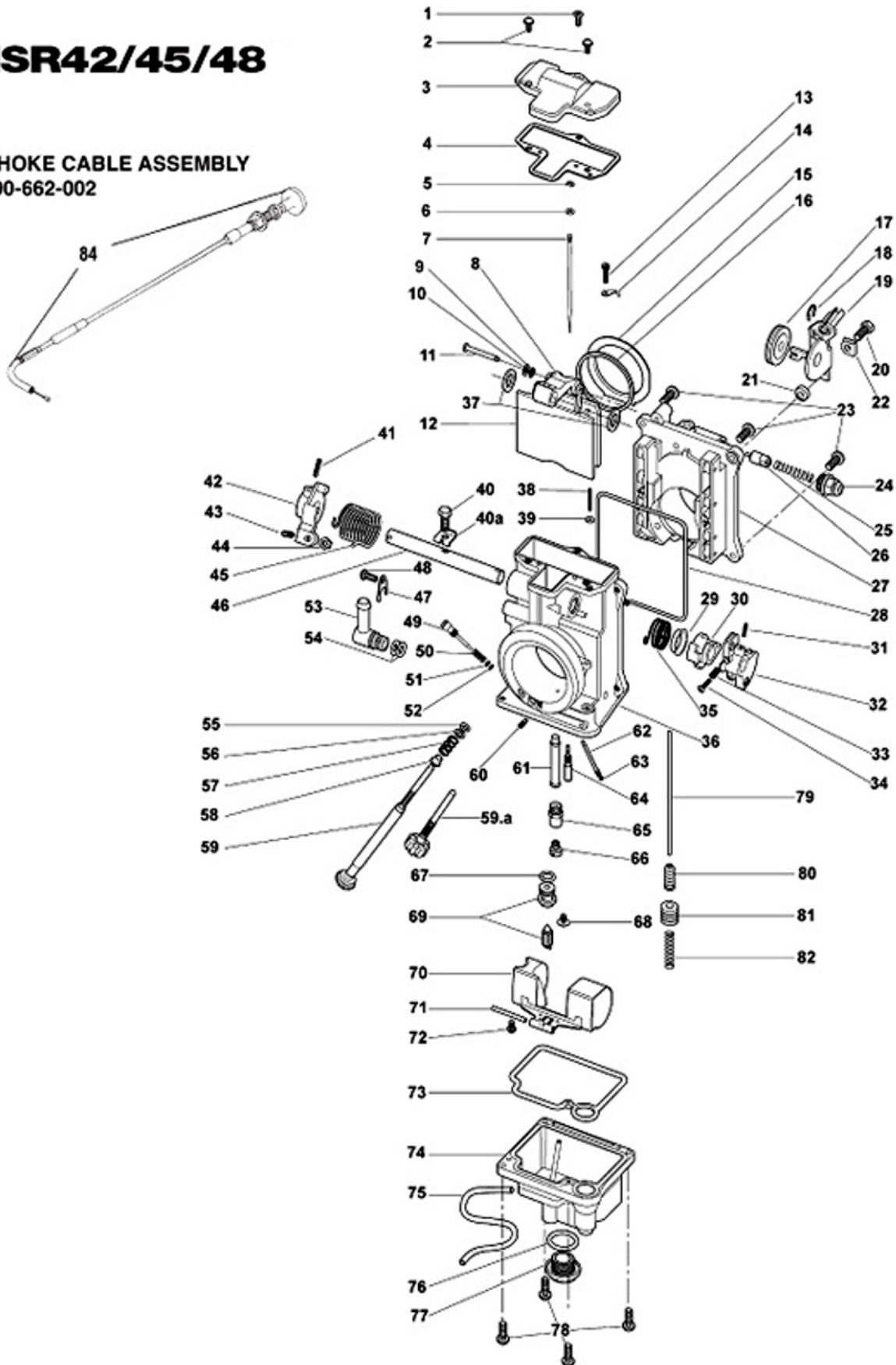



HSR42/45/48 CARBURETOR REPLACEMENT PARTS LIST

#	PART #	DESCRIPTION	#	PART #	DESCRIPTION
1	C5=0410-B	Screw, Top Cover (HSR42/45)	52.	N133.037	O'Ring, Pilot Air
1a.	KHS-028/05	Screw, Top Cover (HSR48)	53.	TM40/27	Fuel Joint
2.	CW2=0414-B	Screw, Top Cover (HSR42/45/48)	54.	KV/10	O-Ring, Fuel Joint
3.	776-39005	Top Cover (42/45)	55.	B30/398	Packing, Idle Adjuster
3a.	HS42/081	Top Cover (HSR48)	56.	VM22/138	Washer, Odle Adjuster
4.	TM42/04	Gasket, Top Cover	57.	730-09018	Spring, Idle Adjuster
5.	BS32/126	E-Ring, Jet Needle	58.	925-15001	Ring, Idle Adjuster
6.	826-03002	Washer, Jet Needle	59.	TM42/32	Idle Adjuster (long)
7.	J8-8DDY01-97	Jet Needle (Series 42)	59a.	990-605-065	Idle Adjuster (Short)
7a.	J8-8CFY02-97	Jet Needle (Series 45) P	60.	BS30/97-00	Air Jet (Blank)
7b.	J8-8CFY15-97	Jet Needle (Series 48)	61.	784-430000-Y-6	Needle Jet (Series 723)
8.	TM42/03	Lever, Throttle Valve (HSR42/45)	62.	TM42/11-70	Nozzle, Accelerator Pump P
8a.	TM42/08-1A	Lever, Throttle Valve (HSR48)	63.	N124.063	O'Ring, Accelerator Pump
9.	B40I/56	E-Ring, Link Lever	64.	VM28/486-25	Pilot Jet (Sportster-20)
10.	b40i/10	Packing, Link Lever	65.	TM42/12	Extender, Main Jet (HSR42/45)
11.	834-23041	Pin, Link Lever	65a.	TN42/12-1A	Extender, Main Jet (HSR48)
12.	TM42/08-3.0	Throttle Valve (Slide)	66.	N100.604-160	Main Jet (45-175, 48-190)
13.	739-13002	Screw, Needle Retainer	67.	616-33003	O'Ring, Needle Valve
14.	TM42/16	Clip, Needle Retainer	68.	VM13/216	Screw, Needle Valve Retainer
TM42/13		Sealing Ring, Throttle Valve (HSR42/45)	69.	786-27001-4.2	Needle Valve Assembly (HSR42/45)
15a.		Sealing Ring, Throttle Valve(HSR48)	69a.	786-27002-1A-4.5	Needle Valve Assembly (HSR48)
16	TM42/10	Seal, Throttle Valve	70.	859-32027	Float Assembly
17.	925-98006	Pulley, Cable Bracket	71.	BV26/22	Pin, Float
18.	53974	E-Ring, Cable Bracket	72.	C2=0410	Screw, Float Pin
19.	TM42/51	Bracket Assly, Cable	73.	606-94028	Packing, Float Bowl
19a.	TM42/53	Bracket Assly, Sportster	74.	TM42/05	Float, Chamber Body
20.	B3=0520-B	Bolt, Bracket	75.	N122.028	Hose, Overflow
21.	VM28/204	Spacer, Bracket	76.	VM28/254	O'Ring, Drain Plug
22.	TM42/38	Plate, Lock Tab	77.	TM32/41	Drain Plug (HSR42/45)
23.	C2=0514-B	Screw	77a.	TM32/41-1D	Drain Plug (HSR48)
24.	640-12001	Starter Nut, Choke	78.	C2=0412-B	Screw, Float Bowl (Short)
25.	VM14/241	Spring, Starter Plunger	79.	TM36/44-1A	Rod, Accelerator Pump
26	N189.192	Starter Plunger	80.	TM36/64	Boot, Accelerator Pump Rod
27.	TM42/06	Body (HSR42/45)	81.	TM36/60	Plunger, Accelerator Pump
27a.	TM42/02	Body (HSR48)	82.	VM14SC13/89	Spring, Accelerator Pump
28.	619-94029	Seal, Spigot Body	83.	N198.063	Rubber Cap, Purge Port
29.	925-19014	Ring (Steel)	84.	990-662-002	Choke Cable
30.	TM42/43	Lever, Accelerator Pump	85.	TM29/31	Pull Choke Assembly
31.	N138.019	Pin, Throttle Lever	86.	BVK28/128	Clip, Rubber Cap
32.	TM42/48	Lever, Throttle			
33.	M12F/46-BB	Spring, Accelerator Pump			
34.	MC-0316-B	Screw, Accelerator Pump			
35.	TM42/47	Spring, Accelerator Pump			
36.	TM42/SS1/01-0	Mixing Body (HSR42/45)			
36a.	TM42/SS1/01	Mixing Body (HSR48)			
37.	B36/95	Packing, Shaft (Plastic)			
38.	TM42/36	Adjusting Screw, Accelerator Pump			
39.	B30/205	O'Ring, Accelerator Pump Screw			
40.	TM40/89	Bolt			
40a.	TM42/17	Plate, Lock Tab for Shaft			
41.	BN38/43	Pin, Return Lever			
42.	TM42/46	ILever, Return			
43.	B30/1069	Adjusting Screw, Throttle			
44.	N3=04	Nut, Throttle Stop			
45.	TM42/19	Spring, Throttle Return			
46.	700-15012	Shaft, Throttle			
47.	TM42/15	Plate, Fuel Joint Retainer			
48.	C2=0410	Screw, Fuel Joint			
49.	604-26014	Screw, Pilot Air			
50.	N133.203	Spring, Pilot Air			
51.	VM12/205	Washer, Pilot Air			

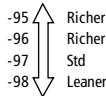

Alternate Parts

Jet Needles:

HSR42	HSR45	HSR48	
J8-8DDY01-95	J8-8CFY02-95	J8-8CFY15-95	Richer
J8-8DDY01-96	J8-8CFY02-96	J8-8CFY15-96	Richer
J8-8DDY01-97	J8-8CFY02-97	J8-8CFY15-97	Standard
J8-8DDY01-98	J8-8CFY02-98	J8-8CFY15-98	Leaner

Accelerator Pump Nozzles:

TM42/11-70	Standard
TM42/11-60	Leaner
TM42/11-50	Leaner

Needle Valve Assemblies:

786-27002-1A-4.5	Standard (HSR48)
786-27001-4.2	Standard (HSR42/45)
786-27001-3.5	Smaller
786-27001-2.3	Pressure Feed Only

Rebuild Kits:

HSR42/45:	KHS-016
HSR48	KHS-031

Notes:

Part Number in **Bold** are included in Rebuild Kits
Part number with strike thru is no longer available

HS40 & TM36-68 & TM40-6 CARBURETOR EXPLODED VIEW

DESCRIPTION	PART #
1. Mixing Body	TM4055/01
2. E-Ring	BS32/126
3. Washer, Needle Clip	826-03002
4. Allens Screw	739-13001
5. Screw, Synch Lock	C5=0514
6. Gasket, Top Cover	TM36/39
7. Top Cover	TM36/59
8. Lever Assembly	TM36/57
9. Gasket, Funnel	TM36/42a
10. Funnel	TM40/03
11. Screw, Throttle Valve Plate	C2=0310
12. Plate Throttle Valve Lever	TM36/12
13. O'Ring, A/P Nozzle	N124.063
14. Pump Nozzle	TM36/43
15. Plug, A/P Nozzle	TM29/14
16. Washer T.V. Lever	M110/59
17. E-Ring, A/P Nozzle	BSW28/79
18. Packing, T.V. Lever	D401/10
19. Clip, Throttle Valve Lever	TM27/05A
20. Ring, Throttle Valve Lever	TM20/65
21. Plate, Throttle Valve Lever	TM27/04
22. Connector Plate, T.V.	TM36/54
23. Jet Needle	J8-9DJY01
24. Throttle Valve	N/A
25. O'Ring, Fuel Screw	N133.037
26. Washer, Fuel Screw	VM12/33
27. Spring, Fuel Screw	N133.206
28. O'Ring, Float Bowl	616-94021
29. Screw, Pilot Fuel	604-26003
30. Float Chamber Body	TM40/12
31. Pilot Jet	VM28/486-17.5
32. Needle Jet	784-13002-Y6
33. O'Ring Drain plug	TM32/41
34. Main Jet	N100.604-165
35. Drain Plug	TM32/41
35b. Drain Plug (Long) TM36	TM32/41-1C
36. Float Assembly	859-32011
37. Pin, Float	VM30/160
38. Needle Valve Assy (TM36)	786-36011-3.3
38a. Needle Valve Assy (TM40)	990-786-044
39. Main Air Jet (Plugged)	BS30/97
40. Screw, Crank Bracket	C5=0512-B
41. Shaft, Throttle	70015004
42. Packing	
43. Pilot Air Jet	BS30/97-1.1
44. Hexagon Nut	N2=03B
45. Adjust Screw	TM36/48
46. Bracket, Bell Crank	TM40/14
47. Pin, throttle Bell Crank	N138.019
48. Lever Assy, Bell Crank	TM40/23
49. Spring, Idle Adjust	N150.025
50. Adjuster, Idle	TM40/91
51. Spring, Throttle Return	TM40/25
52. Screw, Top Cover	CW2=0408
54. Screw, Air Funnel	VM38/133
55. Pin, A/P Locate	BN38/43
56. Lever, Accelerator Pump	TM36/17
57. O'Ring	B30/205
58. Spring, Accelerator Pump	TM40/33
59. Lever, Accelerator Pump	TM36/17
60. Spring, A/P Adjust	M12F/46a
61. Screw, A/P Adjust	MC-0316
62. Hexagon Nut, A/P Adjust	N3=03-B
63. Cap, Vacuum Fitting	N148.013
64. Spring Clip, Vac Fit	BVK28/128

TM36 JETTING

J8-9DZH6-50

VM28/486-12.5

784-13002-P8

N100.604-130

BS30/97-1.0

DESCRIPTION

DESCRIPTION	PART #
65. Cap, A/P Rubber	TM36/64
66. Rod, Accelerator Pump	TM36/44
67. Plunger	TM36/60
68. Spring, Accelerator Pump	VM14SC13/89
69. Plunger, Staqrter	VM38/148
70. Hose	888-23026
71. Screw, N.V. Holder	VM13/216
72. Screw, Flaot Bowl	C2=0412-B
73. Starter Jet	VM17/1002-45
74. Packing, Shaft	VM28/174
75. Ring, A/P Spring	E204049
76. Cap, Starter Cable	VM12/43
81. O'Ring, Starter	N138.198
82. Spring, Starter	VM16/42
83. Guide Holder	640-12001

HS40 Carburetor same as TM40-6 and TM36-68

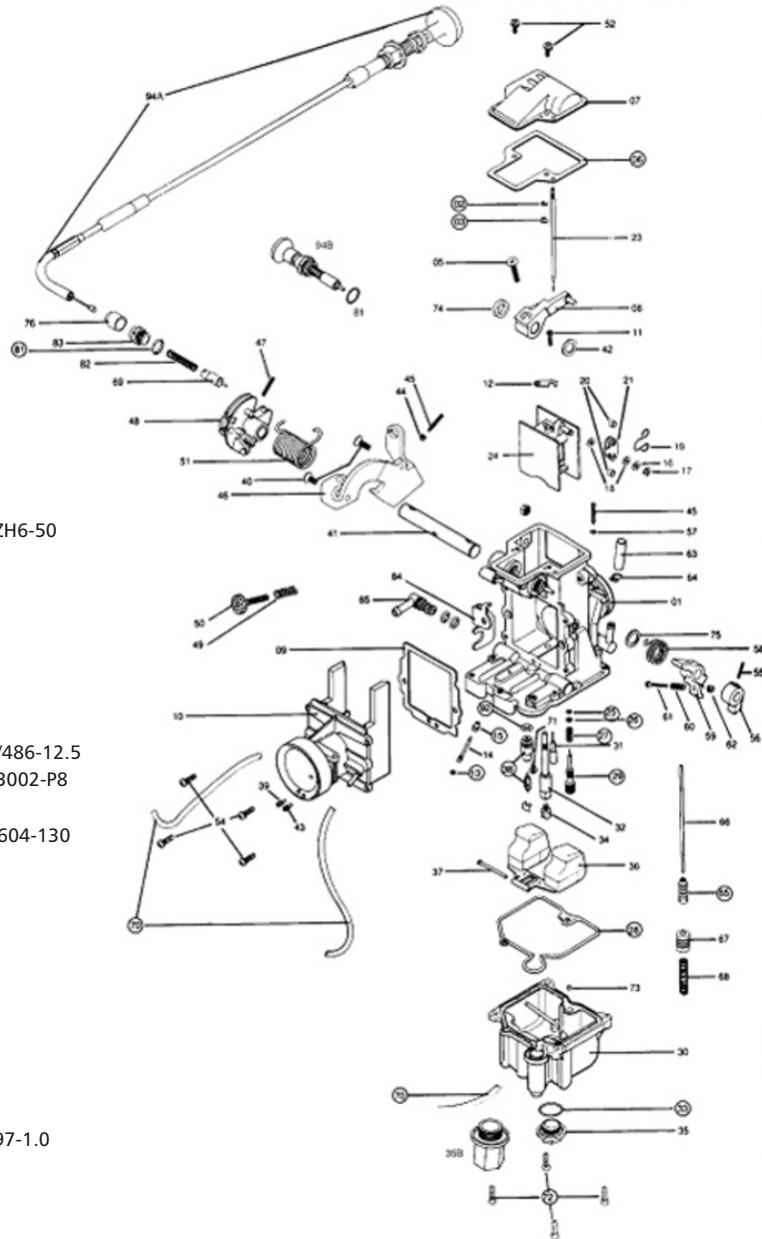

DESCRIPTION

DESCRIPTION	PART #
84. Plate, Fuel Inlet	TM40/26
85. Inlet, Fuel	TM40/27
92. O'Ring, Needle Valve	KV/10
94. Choke Cable Assy	990-662-001
94b. Choke Knob (Short)	TM40/07

TM36 Optional Needles

J8-9EBY01-50, J8-9EBY01-51

TM40 Optional Needles

J8-9DJY01-2.97 (Standard),
J8-9DJY02-2.95, J8-9DJY02-2.96

HS40 Rebuild Kit

KHS-001

Part Numbers in bold are included in rebuild kit
Notes:

Part number with strike thru is no longer available



HS40 Accessories

DESCRIPTION

Carburetor Rebuild Kit

K&N/Mikuni Air Filter (2")

Air Cleaner Cover (Aftermarket - not Cut-outs)

Air Cleaner Cover (Aftermarket - not Cut-outs)

Rubber Flange with Clamp

Choke Cable Assembly

Black

Chrome

PART

KHS-001

RS36/25-200

RS36/24-200-B

RS36/24-200-C

KHS-004

990-662-001

MIKUNI RACING CARBURETORS - RS SERIES

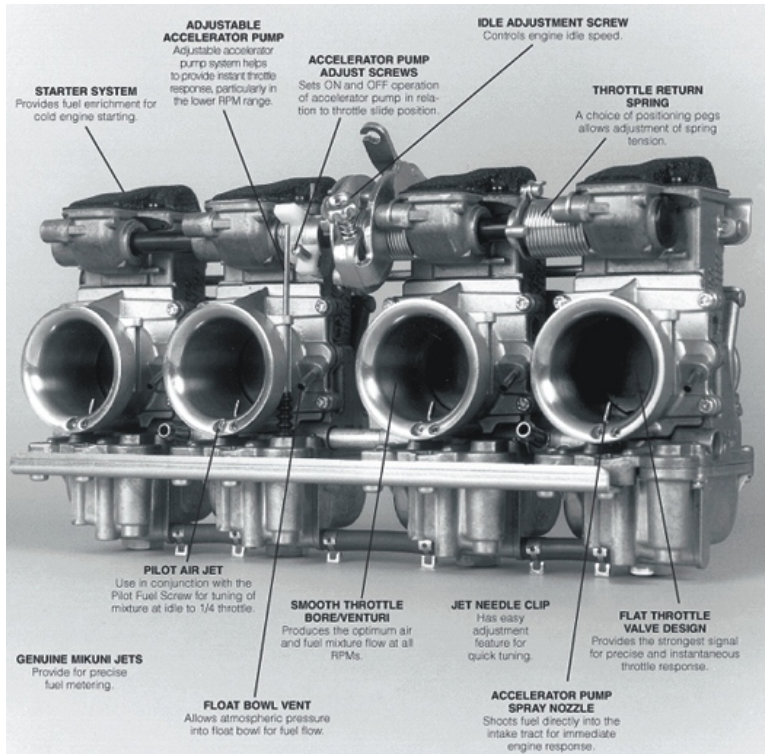

The Mikuni RS Series Carburetors were designed and built in response to the needs of the of the motorcycle road race and drag race teams. Designed to satisfy precise fuel metering and high flow volume required by highly modified race engines, while still providing the smooth controllable throttle response that is needed by any rider pushing his motorcycle to its limits on the race track and under any high performance applications. The carburetors need to meter fuel correctly under a wide range of atmospheric conditions and engine tuning modifications while being easily accessible for trackside tuning changes which need to be made quickly. Designed for in-line four cylinder performance applications, the Mikuni RS Series Radial Flat Slide Carburetor offer superior horsepower gains with their maximum flowing smoothbore induction tract and radial flat slide design. An adjustable accelerator pump system helps to provide instant throttle response, particularly in the lower RPM range.

Special Order Only - Pricing subject to change

Standard Tuning Specifications

Mikuni Kit #	Applications*	Year	Carb Spacing (Throttle Shaft #)	Spigot (O.D.)	Main Jet Size	Jet Needle (Clip Position)	Needle Jet	Pilot Jet	Pilot Screw (Turns)
RS34-D21-K	Suzuki GSX-600 Suzuki GSX-R 750 Suzuki GS 750 All Kawasaki KZ 1000-1100	1988 up to 1990	77-93-77 (700-17011)	40 mm	N100.604-115	J8-9DZH1 (-3)	784-13002 P-4	VM28/486-17.5	1/4-1/2
RS36-D3	Suzuki GSX-R 750 Suzuki GSX-R 1100 Suzuki GS 1000-1150 Kawasaki KZ 1000-1100	up to 1990 up to 1990 All	77-93-77 (700-17011)	42 mm	N100.604-120 N100.604-120 N100.604-130 N100.604-130	J8-9DZH1 (-3)	784-13002 P-4	VM28/486-17.5	1/4-1/2
RS38-D19-K	Suzuki GSX-R 750 Suzuki GSX-R 1100 Suzuki GS 1000-1150 Kawasaki KZ 1000-1100	up to 1990	77-93-77 (700-17011)	42 mm	N100.604-135	J8-9CHY33 (-2)	784-13002 Y-6	VM28/486-17.5	1/4-1/2
RS40-D1-K	Suzuki GSX-R 1990 Suzuki GS Kawasaki KZ Race		77-93-77 (700-17011)	44 mm	N100.604-140	J8-9CHY3 (-3)	784-13002 Y-6	VM28/486-17.5	1/4-1/2"

Kit Prefix Number denotes Carb venturi size in millimeters (i.e. RS36 = 36 mm bore)*NOTE - These are guidelines only.

Push/Pull Throttle Assembly

708-410

A Push/Pull Throttle Assembly is required with the use of all Mikuni Racing Carburetors to assure the positive closing of the carburetor throttles slides against the high vacuum pressures encountered in racing engines. The Mikuni Push/Pull Throttle Assembly includes a twist throttle assembly and both throttle cables and adjusters.



RS SERIES CARBURETORS EXPLODED VIEW

RS34/36/38/40 Radial Flat Slide Smoothbore Carbs

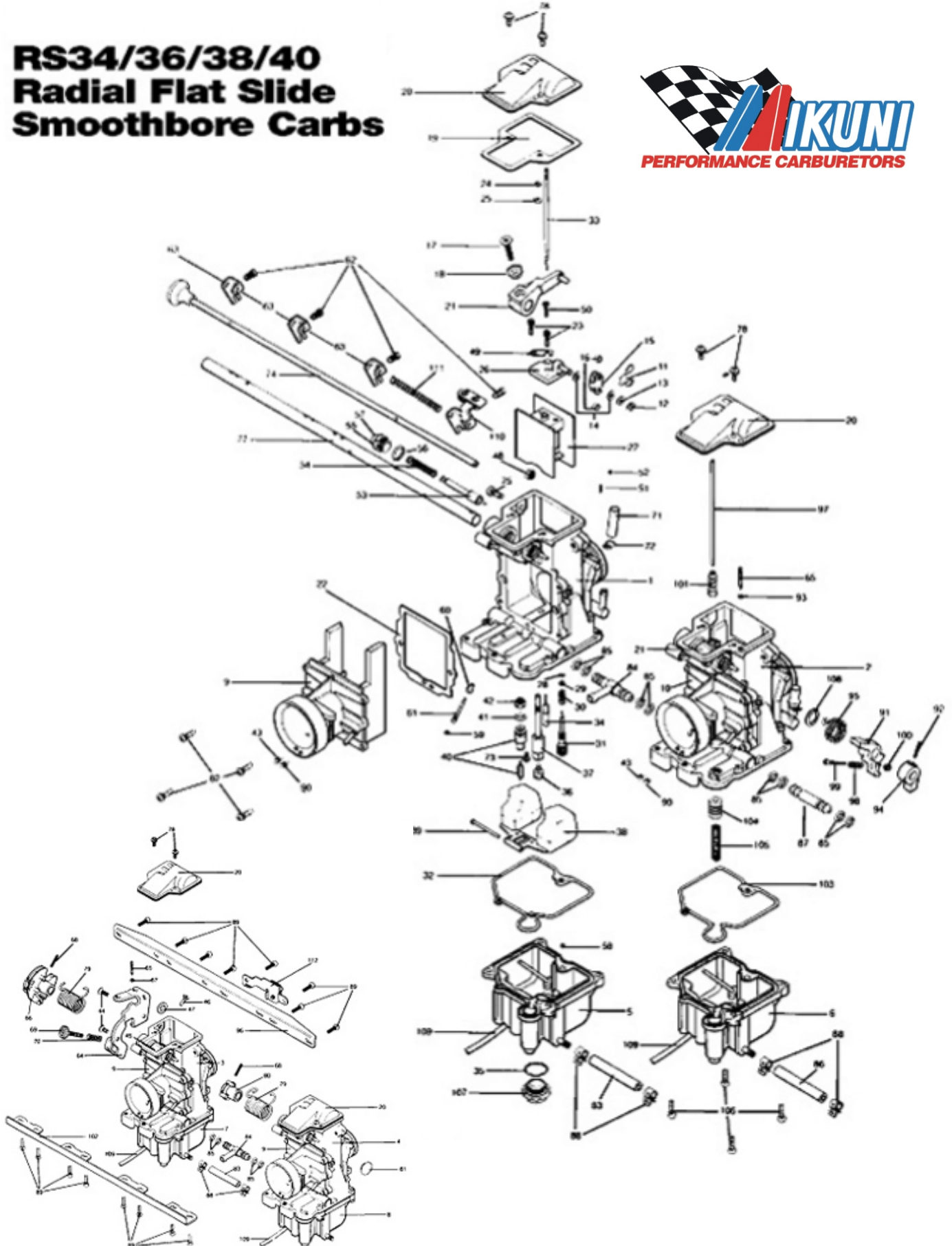



RS SERIES CARBURETORS REPLACEMENT PARTS LIST

DESCRIPTION	PART #	DESCRIPTION	PART #
1. Mixing Body	TM36S551	56. O'Ring, Starter	N138.198
2. Mixing Body	TM36S5515	57. Cap, Starter	N406.211
3. Mixing Body	TM36S5516	58. Starter Jet	VM17/1002
4. Mixing Body	TM36S5517	59. O'Ring Accelerator Pump Nozzle	N124.063
5. Float Bowl Chamber Body	TM36/69	60. Plug, Accelerator Pump Nozzle	TM29/14
6. Float Bowl Chamber Body	TM36/71	61. Pump Nozzle	TM36/43
7. Float Bowl Chamber Body	TM36/73	62. Screw, Start Bracket	N158.052
8. Float Bowl Chamber Body	TM36/75	63. Lever, Starter Shaft	N478.656
9. Air Funnel Body	TM36/27a	64. Bracket, Bell crank	TM36/37d
10. Air Funnel Body	TM36/28a	65. Adjust Screw, Accelerator Pump	TM36/48A
11. Clip, Throttle Valve Lever	TM27/05A	66. Lever Assembly, Bell Crank	TM36/31
12. E-Ring, Throttle Valve Lever	BSW28/70	67. Hexagon Nut, Accelerator Pump	N2=03B
13. Washer, Throttle Valve Lever	M10/56	68. Pin, throttle Bell Crank	N138.019
14. Packing, Throttle Valve Lever	B401/10	69. Adjuster, Idle	739-55003
15. Plate, Throttle Valve Lever	TM27/4	70. Spring, Idle Adjuster	N110.209
16. Ring, Throttle Valve Lever	TM20/65	71. Cap, Vacuum Fitting	N148.013
17. Screw, Synch Lock	C5=0518	72. Spring Clip, Vacuum Fitting	BVK28/128
18. Ring, synch Adjust	Tm36/06	73. Screw Needle Valve Holder	VM13/216
19. Gasket, Top Cover	TM36/39	74. Shaft Assembly Starter	TM36/34a
20. Top Cover Carburetor	TM36/59	75. Pan Head Machine Screw	C2=0508-B
21. Lever Assembly, Throttle Valve #1-2-4	TM36/51	76. Flat Head Machine Screw	C5=0514
22. Gasket, Air Funnel	TM36/42	77a. Shaft, throttle Body Chamber #3	700-17011
23. Screw, 2.5 mm Allen	739-13001	77b. Shaft, throttle Body Chamber #1	700-17012
24a. E-Ring, RS34-36 Needle	VM20/369	77c. Shaft, throttle Body Chamber #3	700-17013
24b. E-Ring, RS38-40 Needle	BS32/126	78. Screw, Top Cover	CW2=0408
25a. Washer, Needle Clip RS34-36	VM26/315	79. Spring, Throttle Return	TM36/46a
25b. Washer, Needle Clip RS38-40	826-03002	80. Lever, Return Spring	TM36/33
26. Connector Plate, Throttle Valve	TM6/54	81. Cap, Shaft End	TM33/36A
27a. Valve, Throttle RS34-36		82. Screw, Air Funnel	VM38/133B
27b. Valve, Throttle RS38-40		83. Hose, Fuel Connect	888-44003
28. O'Ring, Fuel Screw	N133.037	84. Inlet, Fuel "T"	791-23018
29. Washer, Fuel Screw	VM12/33	85. O'Ring, Fuel Joint	616-23002
30. Spring, Fuel Screw	N133.206	86. Hose, Accelerator Pump Fuel	888-404
31. Screw, Pilot Fuel604-26003		87. Joint, Fuel	792-20014
32. O'Ring, Float Chamber Bowl #1, 3, 4	616-94020	88. Clip, Fuel Hose	E100729-BB
33a. Jet Needle RS36 (befroe 12/87)	J8-9CHY01	89. Screw, Bracket	C2=0512-B
33b. Jet Needle RS34, RS36	J8-9DZH02 or 9DZH05	90. Pilot Sir Jet	BS30/97-0.8
33c. Jet Needle RS38, RS40	J8-9CHY03 or 9CHY10	91. Lever, Accelerator Pump	TM36/17
34. Pilot Jet	VM28/489-17.5	92. Pin, Accelerator Pump Locate	BN38/43
35. O-Ring, Drain Plug	VM28/254	93. O'Ring, Accelerator Pump Adjust	B30/205
36. Main Jet	N100.604-	94. Lever, Accelerator Pump	TM36/18
37. Needle Jet (Series 568)	784-13002-P-4	95. Spring, Accelerator Pump	TM36/45
38. Float Assembly	859-32011	96. Plate, Top Bracket	TM36/35
39. Pin, Float	VM30/160	97. Rod, Accelerator Pump	TM36/44
40. Needle Valve Assembly	N149.040-2.8	98. Spring, Accelerator Pump Adjust	M12F/46A
41. O'Ring, Needle Valve	KV/10	99. Screw, Accelerator Pump Adjust	MC-0316-B
42. Filter, Needle Valve	VM18/233	100. Hexagon Nut, Accelerator Pump Adjust	N3=03-B
43. Main Air Jet (Plugged)	BS30/97	101. Cap, Accelerator Pump Rubber	TM36/64
44. Screw, Crank Bracket	C8=0512	102. Plate, Lower Bracket	TM36/36
45. Lever Assembly Throttle Valve #3 Carb	TM36/57	103. O-Ring, Float Chamber Body A/P	616-94021
46. Screw Lever	C5=0514	104a.Plunger, Accelerator Pump 8 mm	TM36/60
47. Packing, Shaft	VM28/174	104b.Plunger, Accelerator Pump 12 mm	TM36/60a
48. Hexagon, Lock Nut	VM18/267	105. Spring, Sccelerator Pump 12 mm	VM14SC13/89
49. Plate, Needle Retainer	TM36/12	106. Screw, Float Bowl	C2=0412-B
50. Screw, throttle Valve Plate	C2=0310	107. Plug, Drain	VM33/77
51. Spring, Starter Shaft	B21/29	108. Ring, Accelerator Pump Spring	E204.040
52. Ball. Starter Shaft	B21/28	109. Hose	888-23026
53. Plunger, Starter	N151.038	110. Lever, Starter Cable	TM36/63
54. Spring, Starter	VM16/42	111. Spring, Starter Bracket	760-06027
55. Guide Holder Starter	640-12002	112. Bracket, Starter Cable	TM36/61

Part number with strike thru is no longer available

TMX SERIES CARBURETORS

The TMX features a flat slide design in a smooth bore venturi to provide improved throttle response and wider powerband. The float system with independently moving floats, working with a main jet enclosed in a baffle chamber, allows the TMX to perform smoothly without hesitation on the roughest terrain.



Carb Part #	Main Jet Size	Pilot Jet Size	Jet Needle	Throttle Valve	Needle Valve	Carburetor Type
TMX35-1	4/042-350	VM22/210-20	J8-6EN11-53	832-014-6.0	786-36004	Motorcycle
TMX35-1-K*	4/042-350	VM22/210-20	J8-6EN11-53	832-014-6.0	786-36004	Motorcycle
TMX38-101	4/042-340	VM22/210-25	J8-6EJ12-57	832-014-4.0	786-36004-A	Snowmobile
TMX38-1	4/042-370	VM22/210-20	J8-6EJ12-55	832-014-3.5	786-36004-A	Motorcycle

* Complete Kit - includes Air Boot Adapter, inner Throttle Cable Wire, Cable End, Main Jets, Pilot Jets, Jet needle, clamp, hose and instructions.

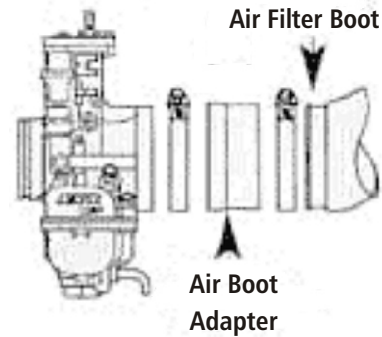
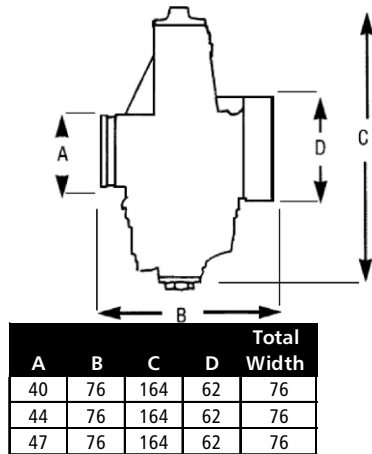

Important Tuning Characteristics

Jet Needle - The Jet Needle is the tapered rod that is positioned in the throttle valve by the E-Clip. The taper of the needle increase the clearance between the Jet Needle and the fixed Needle Jet outlet as the throttle is opened. As the air flow volume increases past the throttle slide, the fuel volume is also increased to maintain the correct air/fuel ratio.

Needle E-Clip - The position of the E-Clip in the Jet Needle is used to correct or change the air/fuel ration between 1/4th and 3/4th throttle valve position. The E-Clip can be raised or lowered on the Jet Needle. To richen the fuel mixture the E-Clip is lowered on the Jet Needle, which in turn raises the Jet Needle. To lean the fuel mixture the E-Clip is raised on the Jet Needle.

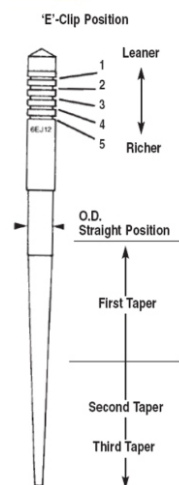

TMX/TMS Carb Air Boot Adapter

An Option available for TMX Carbs, is this Air Boot Adapter required for some applications when replacing a stock OEM carb with the TMX

PART #	DESCRIPTION	DEPTH
TMX/001	Adapter for TMX	30 mm
TMX/006.so	Adapter for TMS	18 mm

To correct the fuel mixture at 1/8th to 1/4th throttle slide position it may be necessary to change the Jet Needle. The Jet Needle will have a series of numbers stamped on it.

For example: 6EJ12-55. The number 55 indicates the outside diameter (O.D.) Of the Jet Needle is 2.55 mm. A smaller O.D. Number gives a richer mixture while a larger number provides a leaner mixture.

TMX35	TMX38	
J8-6EN11-58	J8-6EJ12-60	Leaner ↑ ↓ Richer
J8-6EN11-57	J8-6EJ12-59	
J8-6EN11-56	J8-6EJ12-58	
J8-6EN11-55	J8-6EJ12-57	
J8-6EN11-54	J8-6EJ12-56	
J8-6EN11-53	J8-6EJ12-55	
J8-6EN11-51	J8-6EJ12-54	
	J8-6EJ12-53	



TMX SERIES CARBURETORS

TMX Series Part List

NO.	DESCRIPTION	PART NUMBER
1.	Mixing Body Carb	FM385511
2.	Jet Needle	J8 -See Page 13-25
3.	Cover, Carb Top	776-19014
4.	Lock Nut, Adjuster	B30/247
5.	Cap, Rubber	VM34/282
6.	Adjuster, Cable	VM30/77
7.	O-Ring, Top Cover	616-93009
8.	E-Ring, Needle Clip	BS32/126
9.	Ring, Retaining	TM38/54
10.	Adjuster, Idle Stop	603-25008
11.	Spring, Idle Adjust	N110209
12.	Plunger, Starter Assy	TM38/57
13.	Screw, Air Adjuster	603-36002
14.	Spring, Air Screw	VM15/112
15.	Chamber, Float Bowl	TM38/48
16A.	Valve Seat, Needle Assembly	820-26002-3.5
16B.	Valve Seat, Needle Assembly	820-26002-1.8A
17.	Pilot Jet	VM22/210 -See Tuning
18.	Main Jet	4/042 -See Tuning
23.	Cap, Float Retainer	VM26/42
24.	Screw, Top Cover	CW2=0412
25A.	Throttle Valve (TMX)	832-014 -See Page 33
25B.	Throttle Valve (TMS)	832-017 -See Page 33
26.	Spring T.V.	730-13019
27.	Hose, Vent	888-24011
28.	Screw, Float Bowl	CW2=0308
29.	Hose, Overflow	888-23022
30.	Float, Left Side	859-52021
31.	O-Ring, Drain Plug	BN042-64
32.	Drain Plug	TM38/44
33.	Float, Right Side	859-52020
34.	Gasket, Float Bowl	TM38/52

TMX35/38 Series Exploded View

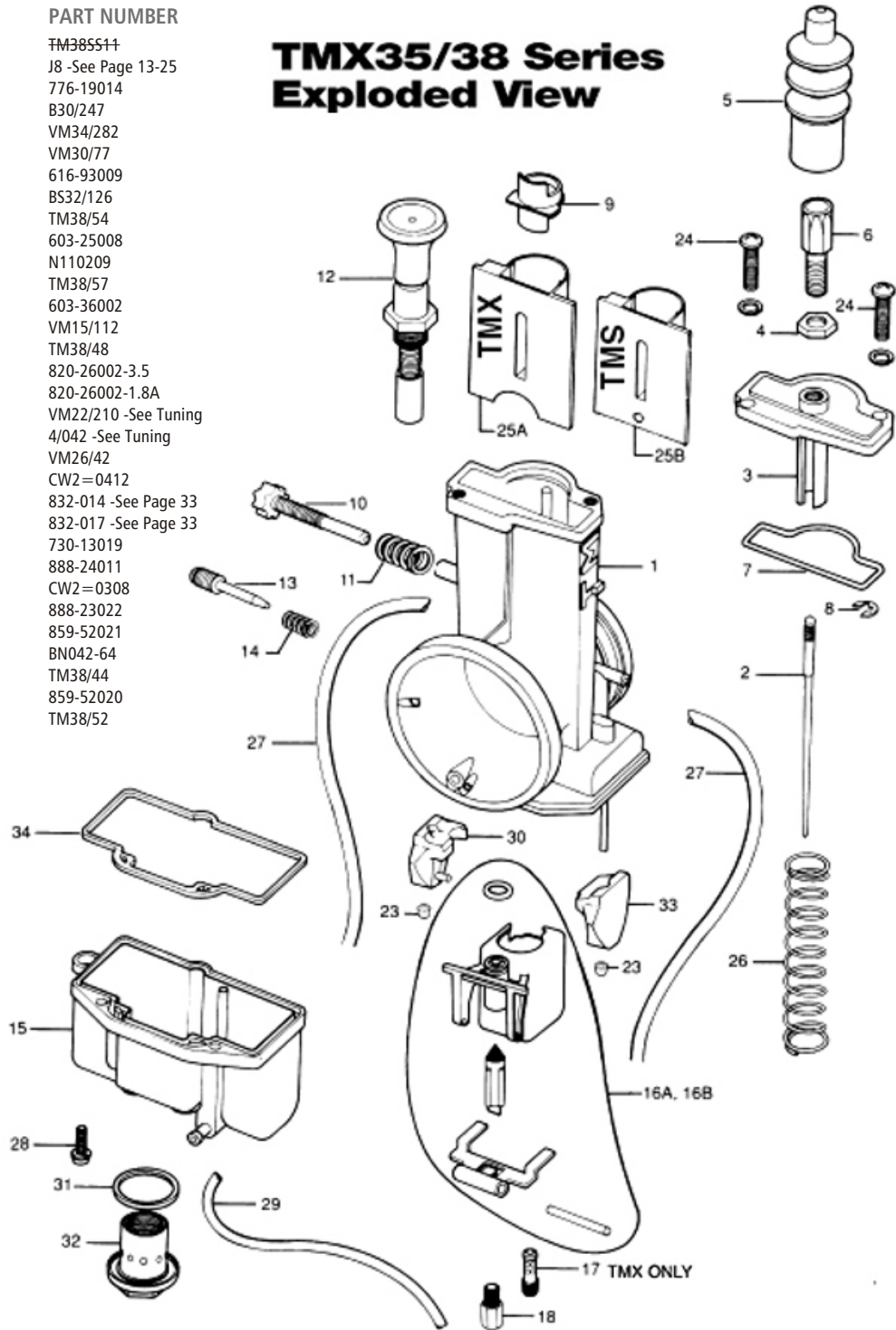

Part number with strike thru is no longer available

TM SERIES CARBURETORS

Mikuni Flat Slide Carburetor

Mikuni's TM Series flat slide carburetors provide a significant performance improvements over older round slide carburetors. Air flows faster, smoother through the TM series venturi and jet blocks due to the flat slide design which helps create a smooth bore effect. The high velocity air flows means a stronger vacuum at the needle jet for more precise metering and better throttle response.

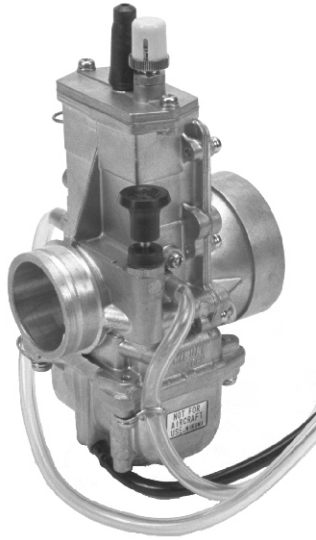

TM Series Flat Slide Carb Dimensions (mm)

Carb Part #	A	B	C	D	Total Width
TM24-8001	31	75	145	44	76
VM28-418	33	82	135	44	76
TM32-1	40	83	160	58	78
TM34-2	40	93	160	50	105
TM36-2	40	83	160	58	78
TM38-85	43	100	170	62	75
TM38-86	42	100	176	54	78
TM33-8012	47	100	170	62	75
TM36-68	43	100	170	62	75
TM40-6	44	100	165	55	

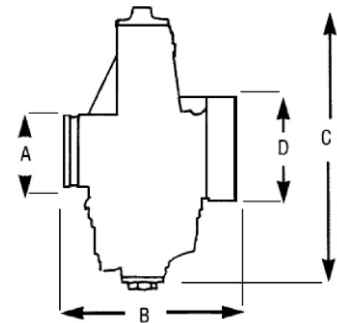

Carb Part #	Size	Main Jet Size	Pilot Jet Size	Needle Jet	Jet Needle	Throttle Valve	Air Jet	Carburetor Type
TM Flatslide Standard Jetting Specifications								
TM24-8001	24 mm	4/042-130	VM22/210-15	784-21005 Q-0	J8-5N13	832-30005-3.0	None	Motorcycle
TM28-418	28 mm	4/042-180	VM22/210-15	VM30/46 P-8	J8-5DP39	832-33001-2.5	None	Motorcycle
TM32-1	32 mm	4/042-250	VM22/210-45	784-24001 Q-2	J8-5FP17	832-39012-4.0	None	Motorcycle
TM34-2	34 mm	4/042-280	VM22/210-50	784-24001 Q-2	J8-5FP17	832-39012-4.0	None	Motorcycle
TM36-2	36 mm	4/042-280	VM22/210-50	784-24001 Q-6	J8-6FJ40	832-43002a-4.0	None	Motorcycle
TM38-102	38 mm	4/042-340	VM22/210-25	785-24001 Q-2	J8-6FJ40	832-43011-4.0	None	Snowmobile
TM38-85	38 mm	4/042-230	VM22/210-22.5	784-24001 Q-2	J8-6FJ41	832-43011-4.0	None	Motorcycle
TM38-86	38 mm	4/042-230	VM22/210-22.5	784-24001 Q-2	J8-6FJ41	832-43011-4.0	None	Motorcycle
TM Flatslide with Accelerator Pump Standard Jetting Specifications								
TM33-8012	33 mm	N100.604-127.5	VM28/486-37.5	784-21111 P-8	J8-5FP96	832-38007-1.5	0.7	Motorcycle
TM36-68*	36 mm	4/042-130	VM22/210-12.5	784-13002 P-8	J8-9DZH6-50	N/A	1	Motorcycle
TM40-6*	40 mm	4/042-165	VM22/210-17.5	784-13002 Y-6	J8-9DJY01	N/A	1.1	Motorcycle

* For TM36-68 and TM40-6 Exploded view and parts list see page 5

Power Jet Kits

560-MK406

Power Jet Kits are used in tow-stroke engine applications to improve mid range throttle response and add additional fuel to wide openrunning conditions, especially with si

Power Jet Kit Installed





TM SERIES FLAT SLIDE CARBURETOR EXPLODED VIEW

TM Flatslide Carburetor

Special Jet Needle For 38 Flatside Carbs	
RICH	6DP04
↕	6FJ40 (Standard)
↕	6FM46
LEAN	6FJ41

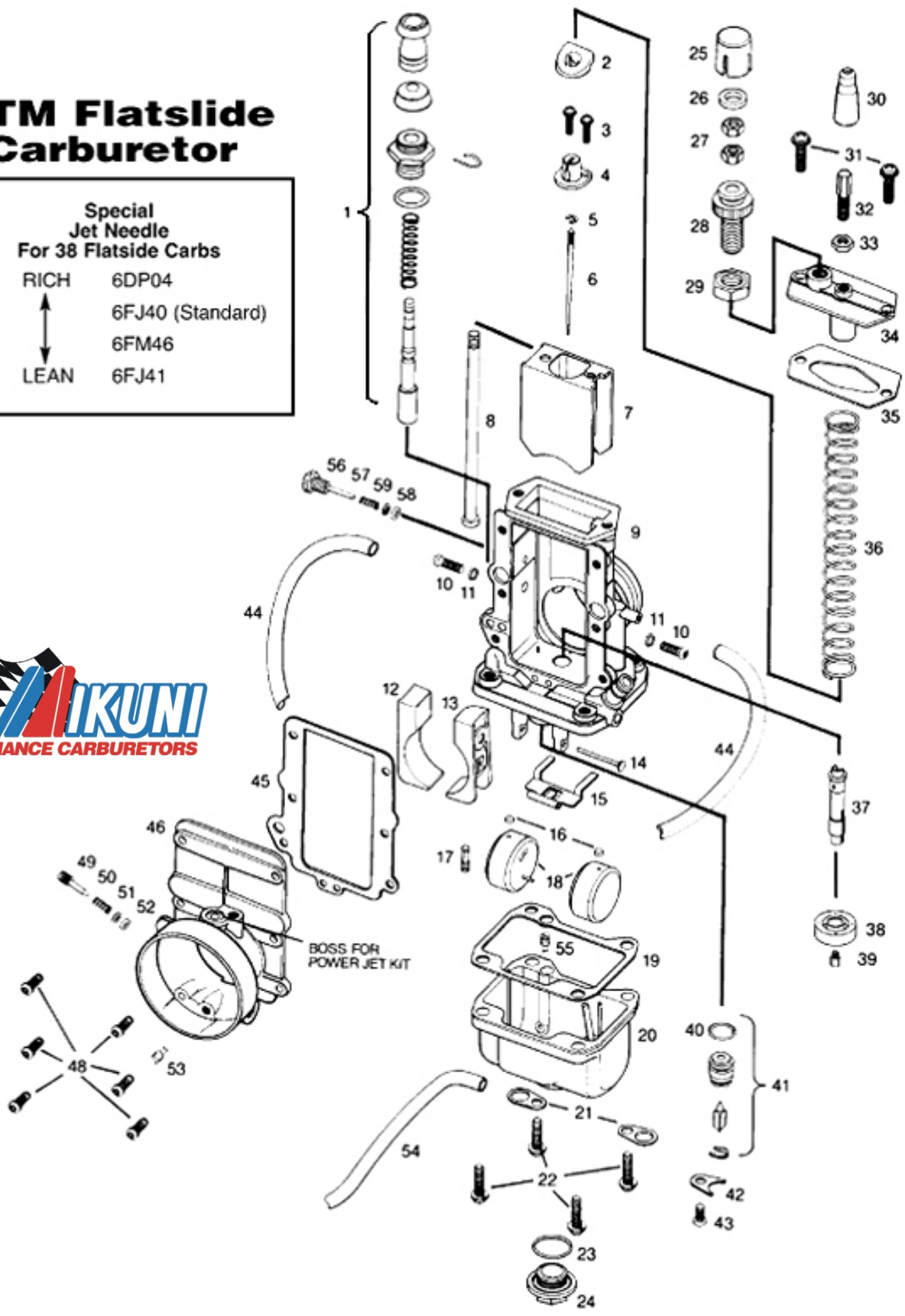



TM SERIES FLAT SLIDE CARBURETOR REPLACEMENT PARTS

Description	VM28-418	TM32-1	TM34-2	TM36-2	TM38-1&3	TM38-85&86
1. Complete Starter Assy	VM26/116 (LT)	VM29/47	VM29/47	VM29/47	VM29/47	VM29/47
2. Nylon Ring	VM26/1046	VM26/1046	VM26/1046	VM26/1046	VM26/1046	VM26/1046
3. Screw w/Lockwasher	CW2=310	CW2=310	CW2=310	CW2=310	CW2=310	CW2=310
4. Cable Connector	VM30/1042	VM30/1042	VM30/1042	VM30/1042	VM30/1042	VM30/1042
5. E-Ring	VM20/369	VM20/369	VM20/369	VM20/369	VM20/369	VM20/369
6. JET NEEDLE	J8-5DP39	J8-5FP17	J8-5FP17	J8-6F J40	J8-6F J40	J8-6F J41
7. Throttle Valve	832-33001-2.5	832-39012-4.0	832-39012-4.0	832-43002-4.0	832-43002-4.0	832-43011-4.0
8. Idle Rod	Not Applicable	Not Applicable	Not Applicable	VM38/159	VM38/159	N/A
9. Mixing Chamber Body	NLA	NLA	NLA	NLA	NLA	NLA
10. Screw, Jet Block	VM38/132	VM38/132	VM38/132	VM38/132	VM38/132	VM38/132
11. Washer (Alum)	VM34/274	VM34/274	VM34/274	VM34/274	VM34/274	VM34/274
12. Jet Block, Left	VM28/1064	VM32/492	VM34/439	VM36-163	VM38/144	TM38/08
13. Jet Block, Right	VM28/1055	VM33493	VM34/440	VM36-164	VM38/145	TM38/09
14. Float Pin	VM30/160	VM30/160	VM30/160	VM30/160	VM30/160	VM30/160
15. Float Arm	N/A	VM36/15	VM36/15	VM36/15	VM36/15	VM36/15
16. Cap, Float Guide Pin	VM26/42	VM26/42	VM26/42	VM26/42	VM26/42	N/A
17. PILOT JET	VM22/210-15	VM22/210-45	VM22/210-50	VM22/210-50	VM22/210-356	VM22/210-22.5
18. Float (Assy)	VM28/694	VM24/236	VM24/236	VM24/236	VM24/236	859-52020
19. Gasket, Float Chamber	VM26/228	VM34/374	VM34/374	VM34/374	VM34/374	VM34/374
20. Float Chamber Assy	VM26/220-15	TM32/02-60	TM32/02-80	TM32/02-100	TM32/02-100	TM38/138
21. Plate, Hose Retaining	VM30/113	VM34/103	VM34/103	VM34/103	VM34/103	VM34/103
22. Screw w/Lockwasher	CW2=0416	CW2=0516	CW2=0516	CW2=0518	CW2=0518	CW2=0516
23. O-Ring	VM26/227	VM28/254	VM28/254	VM28/254	VM28/254	VM28/254
24. Drain Plug	VM28/817	VM28/253	VM28/253	VM28/253	VM28/253	VM28/253
25. Cap, Idle Adjuster	Not Applicable	Not Applicable	Not Applicable	VM35/40	VM35/40	Not Applicable
26. Packing (Rubber)	Not Applicable	Not Applicable	Not Applicable	N138.077	N138.077	Not Applicable
27. Nut	Not Applicable	Not Applicable	Not Applicable	N2=04	N2=04	Not Applicable
28. Idle Adjuster	Not Applicable	Not Applicable	Not Applicable	603-68001	603-68001	Not Applicable
29. Nut	Not Applicable	Not Applicable	Not Applicable	BDC36/35	BD36/35	Not Applicable
30. Rubber Cap	VM26/46	VM/18/228	VM/18/228	VM/18/228	VM/18/228	Not Applicable
31. Screw w/Lockwasher	CW2=0412	CW2=0412	CW2=0412	CW2=0412	CW2=0412	CW2=0412
32. Cable Adjuster	M18F/43a	VM36/83	VM36/83	VM36/83	VM36/83	VM36/83
33. LockNut	B30/247	B30/247	B30/247	B30/247	B30/247	B30/247
34. Mixing Chamber Top	776-15001	776-17001	776-17001	776-19002	776-19002	776-19001
35. Gasket, Top	VM28/1045	VM32/495	M32/495	VM38/127	VM38/127	VM38/127
36. Throttle Valve Spring	730-15001	730-15004	730-15004	730-16003	730-16003	730-16003
37. NEEDLE JET	VM30/46-P-8(175)	785-24001-Q-2(389)	785-24001-Q-2(389)	785-24001-Q-2(389)	785-24001-Q-2(389)	785-24001-Q-2(389)
38. Ring, Main Jet Assy	VM/28/429	VM24/622	VM24/622	VM24/622	VM24/622	VM24/622
39. MAIN JET	4/042-180	4/042-250	4/042-280	4/042-280	4/042-290	4/042-230
40. VM24/559	KV/10	KV/10	KV/10	KV/10	KV/10	KV/10
41. Needle Valve	VM24/557-2.5	786-46001-3.3	786-46001-3.3	786-46001-3.3	786-46001-3.5	786-46001-3.5
42. Plate, Needle Valve	VM24/560	VM24/560	VM24/560	VM24/560	VM24/560	VM38/29
43. Screw	C2=0406	C2=0406	C2=0406	C2=0406	C2=0406	C2=0406
44. Vent Hose	888-23008	888-24001	888-24001	888-24001	888-24001	888-24007
45. Gasket, Front Cover	VM28/1044	VM38/126	VM38/126	VM38/126	VM36/166	VM38/126
46. Front Body, Air Intake	NLA	NLA	NLA	NLA	NLA	NLA
47. Bolt	Not Applicable	Not Applicable	Not Applicable	Not Applicable	BV15/27	Not Applicable
48. Screw	VM38/133-B	VM38/133-B	VM38/133-B	VM38/133-B	VM38/133-B	VM38/133-B
49. Air Screw, Pilot	VM20/584	VM24/622	VM24/622	VM24/622	VM24/622	VM24/622
50. Spring, Pilot Air Screw	M12F/46a	M12F/46a	M12F/46a	M12F/46a	M12F/46a	M12F/46a
51. Washer, Pilot Air Screw	Not Applicable	VM12/33	VM12/33	VM12/33	VM12/33	VM12/33
52. O-Ring, Pilot Air Screw	Not Applicable	N133.037	N133.037	N133.037	N133.037	N133.037
53. MAIN AIR JET	B530/97-1.8	2.5 On Body	2.5 On Body	2.5 On Body	2.5 On Body	2.5 On Body
54. Overflow Hose	888-23007	888-23014	888-23014	888-23014	888-23014	VM24/328
55. Starter Jet*	VM17/1002-15	VM17/1002-60	VM17/1002-80	VM17/1002-80	VM17/1002-100	VM17/1002-40
56. Idle Stop Screw	603-27002	603-16003	603-16003	Not Applicable	Not Applicable	603-16003
57. Spring Idle Screw	VM15/112	VM24/556	VM24/556	Not Applicable	Not Applicable	VM24/556
58. O-Ring	VM14/75	BV32/04	BV32/04	Not Applicable	Not Applicable	BV32/04
59. Washer	VM14/87	Not Applicable	Not Applicable	Not Applicable	Not Applicable	Not Applicable

Starter Jet available in size 15 thru 120; LT - Lever Type; Part number with strike thru is no longer available



TM33-8012 SERIES CARBURETOR EXPLODED VIEW

DESCRIPTION	PART #
1. Screw, Top Cover	CW2-0410
2. Top Cover	TM20-16a1
3. Gasket, Top Cover	TM29/17
4. Screw, Joint Assembly	793-13001
5. Joint Assembly	TM20/71
6. E-Ring	VM20/369
7. Packing	VM26/315
8. Jet Needle	J8-5FP96-3
9. Throttle Valve	832-38007-1.5
10. Gasket, Air Funnel	TM20/62
11. Hose, Vent	VM34/105
12. Air Funnel	TM33/32a
13. Screw, Air Funnel	VM38/133
14. Pilot Air Jet	BS30897-1.1
15. Main Air Jet	BS30/97-0.7
16. Spring, Idle Adjuster	730-07008
17. Idle Adjuster	TM33/38a
18. Clip, Idle Adjuster	N180-160e
19. Pin Float	VM30/160
20. Float Assembly	859-34003
21. Needle Valve Assembly	N133.200-1.8
22. Screw, Needle Valve Holder	VM13/216
23. O'Ring, Needle Valve	KV/10
24. Filter, Needle Valve	VM18/233
25. Ring (Nylon), Main Jet	TM33/35a
26. Ring (Brass), Main Jet	VM18/106a
27. Main Jet	N100.604-127.5
28. Pilot Jet	VM28/486-37.5
29. O'Ring, Float Bowl	616-94012
30. Drain Screw, Float Bowl	N133.363
31. Float Bowl	T33/77
32. Hose, Overflow	888-23043-1ff
33. Screw (Long), Float Bowl	C2=0416
34. Screw (Short), Float Bowl	C2=0414
35. O'Ring, A/P Nozzle	N124.063
36. Accelerator Pump Nozzle	TM29/24
37. Plug, A/P Nozzle	TM29/14
38. Pilot Screw	N138.192
39. Spring, Pilot Screw	N138-187
40. Washer, Pilot Screw	VM12/33
41. O'Ring, Pilot Screw	N133.037
42. Hose, Vent	888-25020-1E
43. Spring, A/P Plunger	730-04003a
44. Accelerator Pump Plunger	TM29/18
45. Cap, A/P Plunger	N150.048
46. Rod, A/P	TM33/46
47. Bolt, A/P Lever	B30/397
48. Lever, A/P	VM38/212
49. Spring, A/P Lever	TM33/47a
50. Main Body	TM33 000 /01-0
51. Screw, Throttle Bracket	C5=0510
52. Throttle Bracket	TM33/33
53. Bell Crank	TM33/44
54. Spring, throttle Return	TM24/21
55. Packing, Throttle Shaft	B36/95
56. Lever, Throttle	VM13/186
57. Washer, Throttle Lever	W4=05
58. Bolt, Throttle Lever	VM28/230
59. Spring, Linkage Lever	VM33/40a
60. Plate, Linkage Lever	VM33/45

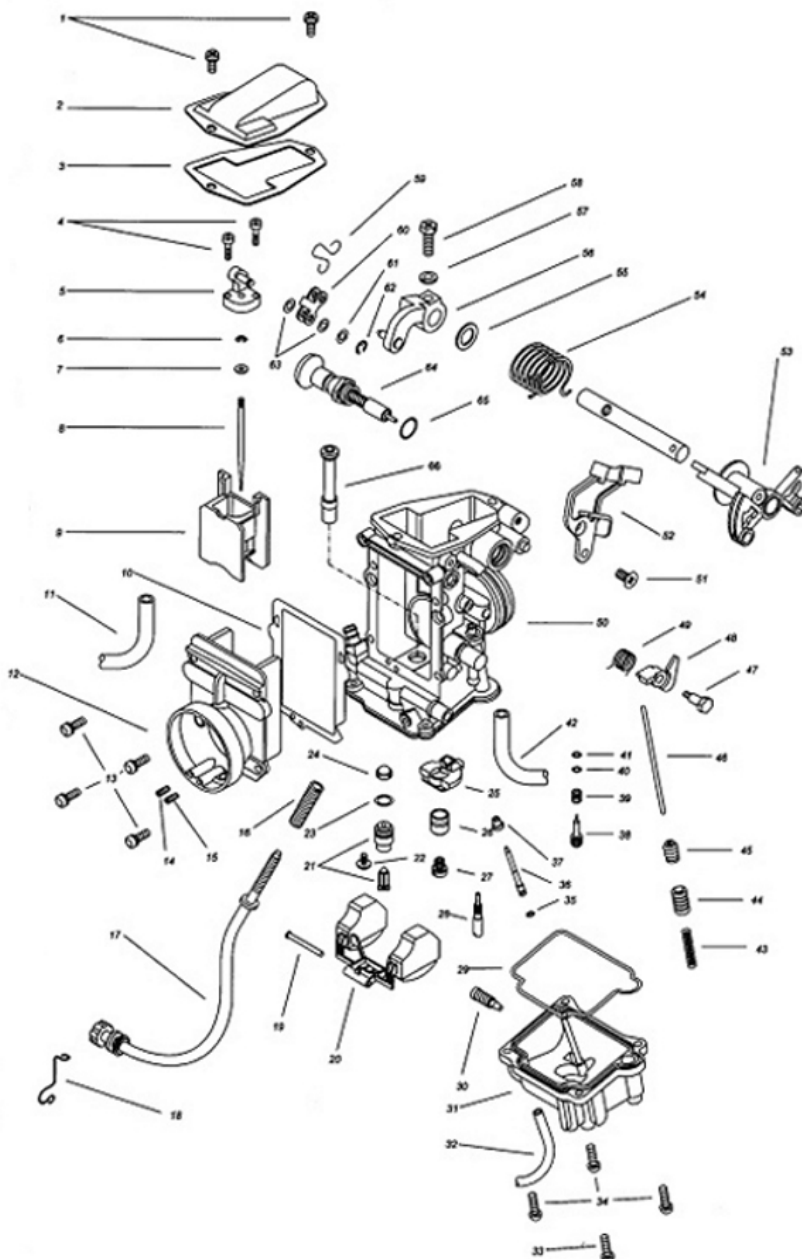

DESCRIPTION	PART #
61. Washer, Linkage Lever	M10/56
62. E-Ring, Linkage Lever	BSW28/70
63. Packing, Linkage Lever	B40i/10
64. Choke Assembly	TM33/49
65. O'Ring, choke Assembly	N138.198
66. Needle Jet	784-24111-P-8

Part number with strike thru is no longer available





VM SERIES ROUND SLIDE CARBURETORS

The most popular high performance single carburetors in the use of motorsports.

Mikuni VM Round Slide Single Carburetors

These are the most popular high performance single carburetors for use in single cylinder motorcycle and ATV applications for motocross, enduro and trail riding, flat track racing and road racing on both 2-stroke and 4-stroke engines.

Performance features for the VM Series Carburetors include a large selection of bore sizes for increased fuel mixture flow to match engine modifications. The VM Series offers a wide range of tuning components to allow precise fuel mixture metering in any application, at any throttle setting, under all riding conditions.



Carburetor Part #	Size (mm)	Main Jet	Pilot Jet	Needle Jet	Jet Needle	Throttle Valve	Main Air Jet	Needle Valve	Notes	Carburetor Type
VM16-519	16	4/042-70	VM22/210-25	VM16/67 D8	J8-3DJ3	VM16/137-2.5	BS30/97-0.5	VM34/39-3.3	Clamp-on Type	Motorcycle
VM18-144	18	4/042-80	VM22/210-30	VM15H1/17-0-0	J8-4F18	VM18/158-3.0	2.5	VM15/172-1.5	Clamp-on Type	Motorcycle
VM20-273	20	4/042-180	M28/1001-22.5	Series 239 O-6 Series 332 N-6	J8-4J13	VM20/491-2.0	VM13/04-0.5	VM15/172-1.5	YSR 50 Flange Type	Motorcycle
VM22-133	22	4/042-100	VM22/210-30	Series 257 N-8	J8-4D20	VM26/21-2.0	2.5	VM26/26-2.0	Flange Type	Motorcycle
VM24-512	24	4/042-210	VM22/210-40	Series 864 N-8	J8-5L14-4	VM26/21-1.5	MD13/24-0.8	VM26/26-2.0		Motorcycle
VM26-606	26	4-/42-190	M28/1001-22.5	Series 332 O-0	J8-5E75	VM24/361-1.5	VM13/04-0.5	VM26/26-2.5	Spigot Type	Motorcycle
VM26-8074	26	4/042-190	VM22/210-60	VM28/86-N-8	J8-5F21	VM28/56-2.0	BS30/97-0.5	VM26/26-2.5	Spigot Type	Motorcycle
VM28-418	28	4/042-180							Flat Slide	Motorcycle
VM30-164	30	4/042-270	VM22/210-35	VM34/05 Q-0	J8-6DH2	2	2.5 Body	1.5	Round Slide	Snowmobile
VM30-83	30	4/042-250	VM22/210-40	VM34/05 P-5	J8-6F5	VM34/110-2.5	BS30/97-2.0	VM34/39-3.3	Spigot Type	Motorcycle
VM32-193	32	4/042-200	VM22/210-35	VM34/05 Q-6	J8-6DP17	VM32/65-3.0	BS30/97-2.0	VM34/39-3.3	Spigot Type Right Side Idle Screw	Motorcycle
VM32-282	32	4/042-280	VM22/210-35	VM34/05 Q-0	J8-6DH4	2.5	2.5 Body	1.5	Round Slide	Snowmobile
VM32-33	32	4/042-200	VM22/210-35	VM34/05 Q-6	J8-6DP17	VM34/110-3.0	BS30/97-2.0	VM34/39-3.3	Spigot Type	Motorcycle
VM34-168	34	4/042-260	VM22/210-35	VM34/05 Q-2	J8-6DH4	VM34/110-2.5	BS30/97-2.0	VM34/39-3.3	Spigot Type - 11.5 mm Bell, Lge Fuel Inlet	Motorcycle
VM34-275	34	4/042-260	VM22/210-35	VM34/05 Q-2	J8-6DH4	VM32/65-2.5	BS30/97-2.0	VM34/39-3.3	Spigot Type Right Side Idle Screw	Motorcycle
VM34-389	34	4/042-330	VM22/210-30	VM34/05 Q-0	J8-6DH3	2.5	BS30/97-2.0	1.5	Round Slide	Snowmobile
VM36-4	36	4/042-310	VM22/210-35	VM34/05 Q-5	J8-6FJ6	VM36/36-2.5	BS30/97-2.0	VM34/39-3.3	Spigot Type	Motorcycle
VM38-21	38	4/042-360	VM22/210-40	VM34/17 Q-0	J8-6DH3	VM38/24-2.5	2.5 Body	VM28/163-1.5	Round Slide	Snowmobile
VM38-9	38	4/042-330	VM22/210-30	VM34/17 Q-2	J8-6DP17	VM38/24-2.5	BS30/97-0.5	VM34/39-3.3	Spigot Type	Motorcycle
VM44-3	44	4/042-310	VM22/210-35	VM44/10 AA-5	J8-7F7	VM44/23-2.5	BS30/97-0.5	VM34/39-3.3	Spigot Type	Snowmobile

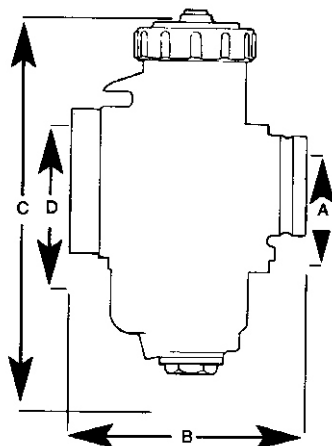

VM Series Carburetor Dimensions (mm)						
Carb Part #	A	B	C	D	Total Width	
VM18-144	Clamp-on 22 I.D.	67	108	32	61	
VM20-273	Flange 50.8 Bolt Center	66	115	43	76.5	
VM22-133	Flange 49 Bolt Center	85	114	43	82	
VM24-512	35	80	116	43	82	
VM26-606	35	93	122	44	82	
VM26-8074	35	93	122	44	82	
VM30-83	40	93	137	58	83	
VM32-193	40	102	142	58	83	
VM32-33	40	102	142	58	83	
VM34-275	40	93	137	58	83	
VM36-4	43	116	152	62	79	
VM38-9	43	116	154	62	79	
VM44-3	52	116	193	70	79	

VM SPIGOT MOUNT TYPE CARBURETORS

Mikuni VM Spigot Mount Carburetor Exploded View

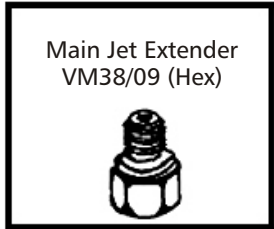
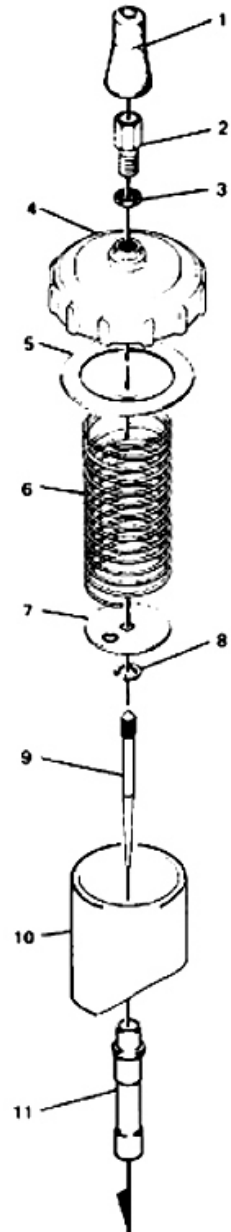
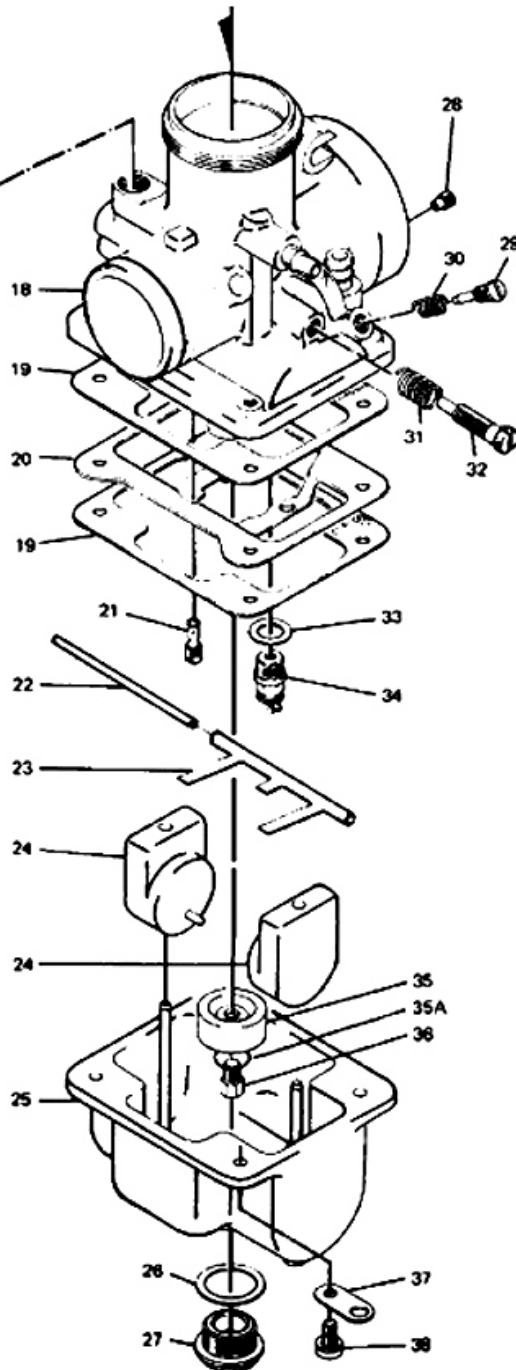
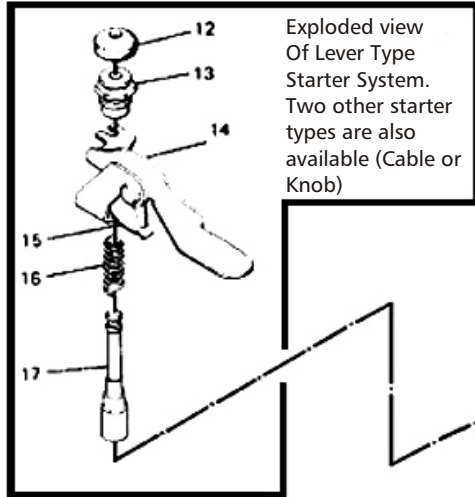

VM SERIES (SPIGOT MOUNT) REPLACEMENT PARTS

ITEM # & DESCRIPTION	VM26	VM28	VM30	VM32	VM34	VM36	VM38	VM40	VM44	
1. RUBBER CAP, Throttle Cable	VM26/46									
2. CABLE ADJUSTER	M21/14									
3. LOCKNUT, Cable Adjuster	B30/247									
4. TOP, Mixing Chamber	VM26/56			VM34/27		VM36/09		VM44/05		
5. GASKET, Mixing Chamber Top	VM26/57			VM34/29		VM36/06				
6. SPRING, Throttle Valve	VM28/257		VM34/50	VM34/55				VM44/13		
7. PLATE, Spring Seat	VM28/132			VM34/31		VM35/09		VM44/09		
8. CLIP, Needle Positioning	VM20/369									
9. NEEDLE	J8-* (#5 Series) page 31			J8-* (#6 Series) page 32				J8-* (#7 Series) page 36		
10. THROTTLE VALVE (SLIDE)	VM28/56-*			VM34/110-*		VM36/36-*	VM38/24-*	VM44/02-*		
11. NEEDLE JET	VM28/86-*	VM30/38-*		VM34/05-*			VM34/17-*	VM44/10-*		
12. RUBBER CAP, Starter Plunger	VM20/455									
13. FITTING, Starter Plunger	VM26/116	VM20/456								
14. LEVER, Starter	VM28/135	VM28/497		VM28/124		VM32/53		VM36/58		
15. SPRING PLATE, Starter Level	VM26/09		VM32/17							
16. SPRING, Starter Plunger	VM16/42									
17. PLUNGER, Starter	VM15/62	VM18/144								
18. BODY, Mixing Chamber										
19. GASKET, Float Bowl	VM28/129		VM30/103		999-631-010	VM36/20				
20. BAFFLE PLATE, Float Bowl				VM34/72		VM36/40	VM44/12			
21. PILOT JET	VM22/210-* page 26									
22. PIN, Float Arm Hinge	BV26/22									
23. ARM, Float	VM28/166			VM34/73		VM36/15				
24. FLOAT	VM28/164			VM34/61		VM24/236				
25. BOWL, Float	See page			VM34/68		VM36/07	VM44/04			
26. WASHER, Main Jet Plug	VM28/134			4/053				VM28/134		
27. DRAIN PLUG, Main Jet	VM28/133			VM34/42		VM28/253	VM38/08	VM28/133		
28. AIR JET	BS30/97-* page 26									
29. AIR ADJUSTING SCREW	VM20/214									
30. SPRING, Air Adjusting Screw	M12F/46A									
31. SPRING, Idle Adjusting Screw	M20/11									
32. IDLE ADJUSTING SCREW	VM24/224		VM28/142	VM24/224		VM22/171	VM24/224			
33. WASHER, Needle Valve	VM26/25	B34/52-0.8, 1.0								
34. NEEDLE VALVE & SEAT ASSY	VM26/26	VM34/39-*						or VM38/11-3.5		
35. RING, Main Jet	VM28/228		VM36/17					VM28/228		
36. MAIN JET	4/042-* see page 25									
37. PLATE, Vent Tube Anchor	VM28/79									
38. SCREW, Float Bowl ¹	CW2=0416			CW2=0518		CW2=0516	CW2=0518			

* - Indicates jet or needle size required to complete part #.





VM SERIES ROUND SLIDE FLANGE STYLE (CLAMP-ON)



DESCRIPTION

1. Rubber Cap, Throttle Cable
2. Cable Adjuster
3. Nut, Cable Adjuster
4. Top, Mixing Chamber
5. Spring, Throttle Valve
6. Clip, Jet Needle Retaining
7. E-Ring, Jet Needle Positioning
8. Jet Needle
9. Throttle Valve (Slide)
10. Rubber Cap, Starter Plunger
11. Fitting, Starter Plunger
12. Spring, Starter Plunger
13. Starter Plunger
14. Spring Plate, Starter Lever
15. Starter Lever
16. Washer, Starter Lever
17. Nut, Clamp Bolt
18. Sealing Ring, Rubber
19. Ring, Insulator
20. Pilot Jet
1. Needle Jet
22. Main Jet
23. Gasket, Float Bowl
24. Float Bowl
25. Screw, Float Bowl
26. Air Adjusting Screw
27. Spring, Air Adjusting Screw
28. Spring, Idle Adjusting Screw
29. Idle Adjusting Screw
30. Bolt, Clamp
31. Washer, Needle Valve
32. Needle Valve & Seat Assembly
33. Float
34. Pin, Float
35. Hose, Overflow

PART

- VM18/67
- M21/14
- BS30/247
- VM16/40
- VM18/170
- VM18H1/38
- VM20/369
- J8-4F18
- VM18/158-3.0
- VM20/455
- VM20/456
- VM16842
- VM18/144
- ~~VM18/151~~
- VM18/215
- BV26/118
- N1=05
- VM18/326
- VM18/327
- VM22/210-30
- VM15H1/17-O-
- 4/042-80
- VM17/161
- VM18/161
- CW2=0414
- VM20/305
- VM15/112
- VM15/112
- VM18/164
- VM16/65
- VM15/07
- VM158172-1.5
- VM17/159
- BV26/22
- ~~VM16/06~~

VM18-144 Exploded View Clamp-on Style

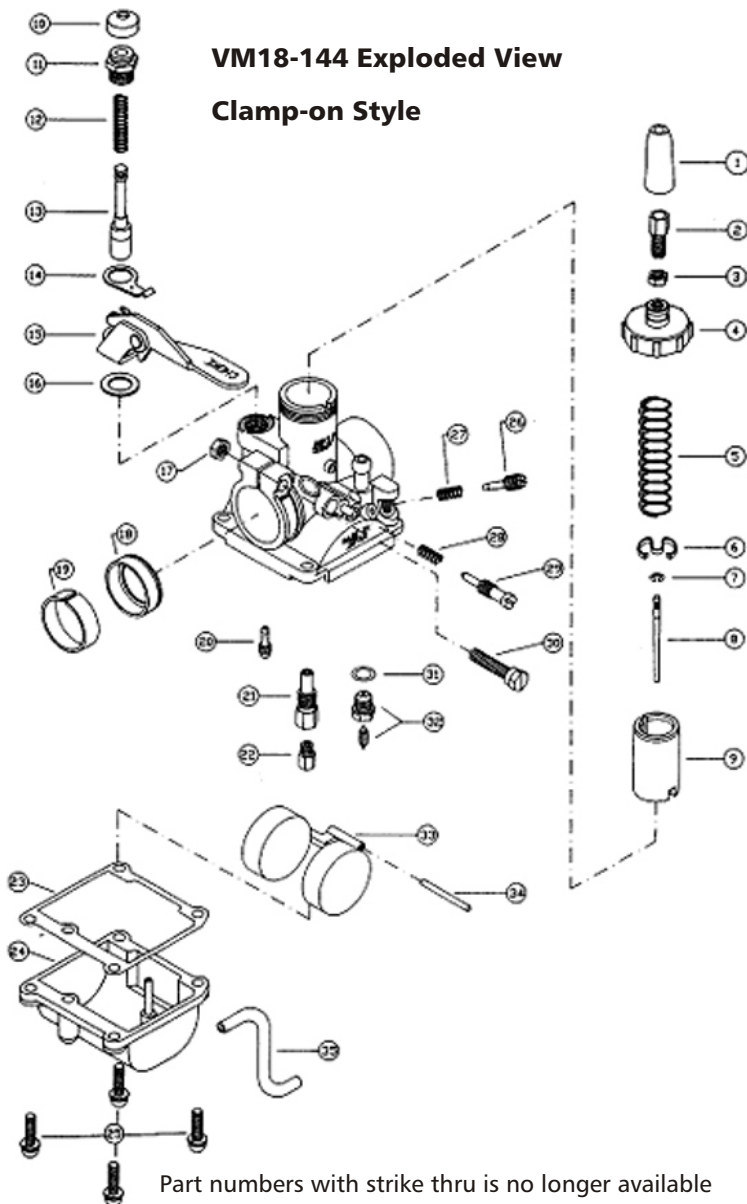

Part numbers with strike thru is no longer available



FLOAT BOWLS

Float Bowl

- Fits VM36 & 38 Mikuni Carbs
- O-Ring
- Washer

- VM36/102B
- BV32/04
- VM20/169

BN SERIES CARBURETORS (WATERCRAFT)

High Performance BN Series Square Pump Type

The High Performance Super BN Carburetors were specially designed to meet the needs of high horsepower racing watercraft. Mikuni has achieved greater air flow and fuel flow through extensive testing to provide maximum output. Special needle valves and springs give optimum "pop-off" with larger high and low speed jets. Super BN Series Carburetors feature: improved air flow, higher capacity fuel pump, externally adjustable metering screws and replaceable fixed jets for easy high and low speed tuning.

BN34-28-8010

Standard 34 mm Replacement

BN38-34-8075

Performance dual 38 mm carburetors with a shaft coupling included. Designed exclusively for dual 38 mm kits using most after market manifolds and flame resistors. Features a 2.0 Vitron needle valve, #65 pilot (slow) jet, #107.5 Main (high) jet, cold starter fitting and angled fuel fitting.

BN38-34-8113

Performance single 38 mm to replace most standard BN or Super BN carburetors. Features a Vitron 2.0 needle valve, extended throttle shaft for dual or triple applications, #65 pilot (slow) jet, #107.5 Main (high) jet and primer fitting.

BN44-40-12

Equivalent to OEM carburetor supplied on Jet Ski JS440 (1987 model), but features improvements such as metal fuel inlet and cover and a slotted throttle shaft.

BN44-40-8067

Performance single 44 mm for most sit-down models requiring larger jets. Features a Vitron 2.5 needle valve, extended throttle shaft for dual or triple applications, #120 pilot (slow) jet, #140 Main (high) jet and primer fitting.

BN44-40-43

Original equipment replacement for Yamaha Super Jet. Features standard stock jetting, butterfly choke, and 44 mm bore.

BN44-40-8052

Performance single 44 mm carburetor with extended throttle shaft to make dual kits. Designed to give maximum performance with a single carburetor. Features a Vitron 2.3 needle valve, #100 pilot (slow) jet, #125 main (high) jet, primer type cold starter fitting and angled fuel fittings.

Pro Racing Super BN 46 series

BN46-42-8002

Performance single 46 mm carb with extended throttle shaft to make dual kits. The Super BN46 features a large 48 mm intake tapering to a 42 mm venturi and controlled by a 46 mm butterfly valve. Comes with a Vitron 2.5 needle valve, #120 pilot (slow) jet, #150 main (high) jet, primer type cold starter fitting and angled fuel fittings.

Note: Bolt pattern is the same as BN44, some manifold porting may be necessary to maximize air flow.

BN I Series Type Carburetors (Special Order)

BN40I-38-24.so

OE on the 1998 SeaDoo GTI, GTS, GS. Features a 167.5 hi-speed jet, 70 low-speed jet, 1.5 needle valve and 95 gr. Spring.

BN40I-38-26.so

OE on the 1998 SeaDoo GSX, SPX-MAG Side.

BN40I-38-27.so

OE on the 1998 SeaDoo GSX, SPX-PTO Side. Features a 140/142.5 hi-speed jet, 67.5 low-speed jet, 1.5 needle valve and 95 gr. Spring.

BN40I-42-B4.so

Original Dual Carbs on the 1998 SeaDoo GSX, GTX-LTD. Features 162.5 hi-speed jet. 77.5 low-speed jet, 2.0 needle valve and 95 gr. Spring



BN34-28-8010



BN44-40-43



BN44-40-8052

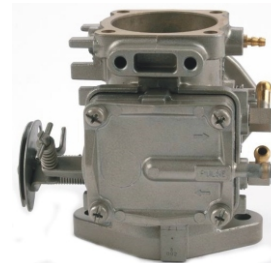

BN46-42-8002



BN CARBURETOR ACCESSORIES

Super BN 38 Needle Valve Kit BN38NV

- Replacement kit for Super BN38, contains a 2.0 needle valve, and 115 gram spring with approximately 32lbs pop off and 80 gram spring for 21 lbs pop off.

Super BN 44 Needle Valve Kit BN44 NV1

- Replacement kit for Super BN44, contains a Viton 2.3 needle valve and 65 gram spring for 15 lbs pop off. Instructions included.

Super BN44 Needle Valve Kit BN44 NV2

- Replacement kit for High Performance Super BN44 and 46, contains a 2.5 needle valve and 80 gram spring for 14lbs pop off. Instructions included.

Round BN Needle Valve Kit BN38/44NV

- Replacement needle valve kit for standard BN carbs with round fuel pump.
- Includes 2.5 Needle Valve, 65 gram spring, washer for 14 lbs "pop-off"

Coupling Kit BN/001

Allows two carburetors to be connected for dual carb setups



Throttle Shaft Rebuild Kits

Kit includes butterfly valve, shaft, seals, screws and instructions.

DESCRIPTION	PART #
SBN 38mm	BN/038TV
SBN 44mm	BN/044TV
SBN 46mm	BN/046TV

Tuning Components for Super BN Series Carburetors

Pilot (Slow Speed) Jets

N100.606-(jet size)

N100.606- Sizes run from 50 through to 150 in increments of 2.5

Main (High Speed) Jets

N102/221-(jet size)

N102.221- Sizes run from 50 through 200 in increments of 2.5.

Needle valve Assembly

786-35015-(needle size)

Solid Needle, Vitron

786-35015- Sizes are 1.5, 2.0, 2.3 and 2.5

Needle Valve Arm Springs

Different spring rates to vary your pop-off pressure.

PART #	RATE	COLOR	LENGTH
730-03030	65 grams	Shiny Silver	14.6 mm
730-03027	115 grams	Platinum	16.7 mm
730-03027-T	95 grams	Dull Silver	15.7 mm
730-03033	80 grams	Black	14.6 mm

BN REBUILD KIT EXPLODED VIEW- (ROUND PUMP CARB TYPE)

Mikuni BN Round Pump Rebuild Kit

MK-BN38/44

- For BN34, BN38 & BN44 Round Pump
- Kit includes circled items 1-15

Winderosa BN Round Pump Rebuild Kit 462140

598-1400

- Kit includes circled items 4-12

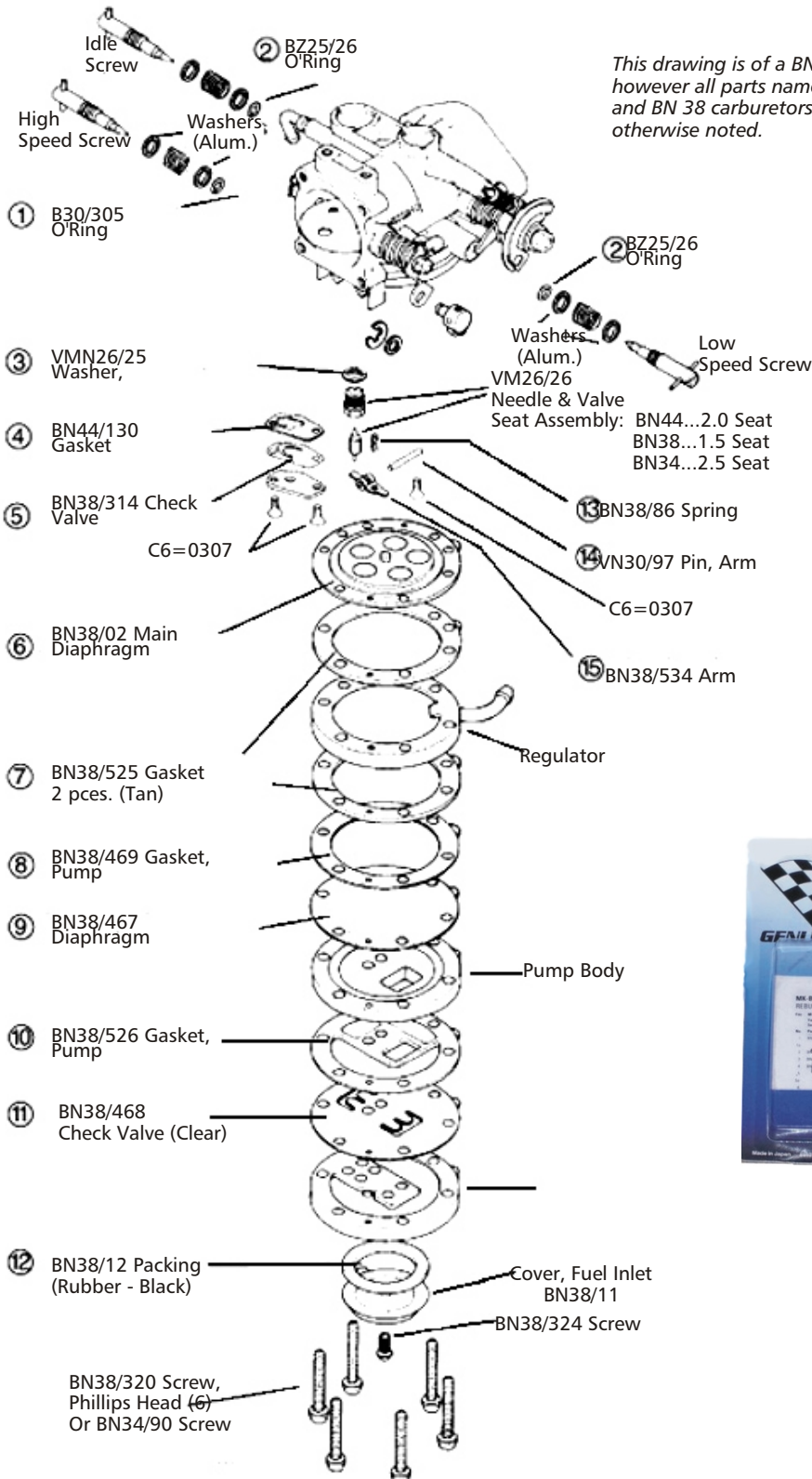

MK-BN38/44



BN REBUILD KIT EXPLODED VIEW- (SQUARE CARB TYPE)

Mikuni BN Square Pump SPR Rebuild Kit

MK-BN38/44 SPR

For Super BN38, BN44 and BN46, BN38I, BN40I Square Pump Styles

- Kit includes circled items 1-16 to rebuild 1 carburetor

Winderosa BN Square Pump Rebuild Kit 451460

598-1460

- Kit includes circled items 1-6, 8-13, 16

PART #	DESCRIPTION
1.	BM38/547 Gasket, Pump (2)
1a.	616-72001 O'Ring, Pump Body
2.	BN34/97 Diaphragm, Pump (Clear)
3.	BN34/124 Check Valve (2) (Clear)
4.	BN34/125 Grommet, Check Valve (2)
5.	BN34/100 Diaphragm, Damper (BN44 only)
5a.	BN34/129 Diaphragm, Damper (BN38 & later BN44)
6.	BN34/101 Gasket, Damper (BN44 only)
6a.	616-92007 O'Ring (BN38 & later BN44)
7.	BN44/146 Filter
8.	B30/305 O'Ring, Hi Speed
9.	MD12/16 O'Ring, Low Speed
10.	KV/10 O'Ring, Needle Valve
11.	BN34/123 Gasket, Valve Body
12.	BN34/107 Check Valve (Clear)
13.	730-03027 Spring, Arm (115 gr)
13a.	730-03030 Spring, Arm (65 gr)
13b.	730-03027 Spring, Arm (95 gr)
14.	VM30/97 Pin, Arm
15.	BN38/534 Arm (Stainless)
16.	BN44/145 Diaphragm Assembly

BN Carburetor Replacement Parts

(Items 17-43 for reference only, NOT included in Rebuild Kit)

17.	BN34/120-30 Screw w/2washers Stainless (2 pces)
18.	BN34/95B Cover, Pump
19.	BN34/98 (N/A) Body Assy Pump (BN44 only)
19a.	BN34/128 Body Assy Pump (BN38 & later BN44)
20.	BN44/109 Stop Screw, Idle (BN44 only)
20a.	BN34/82 Stop Screw, Idle (BN38 & later BN44)
21.	BN38/39 Washer (alum)
22.	BN38/341 Spring, Idle (BN44 only)
22a.	BN38/344 Spring, Idle (BN38 & later BN44)
23.	B26/03 Cap (BN44 only)
23a.	BN44/118 Cap w/tab (BN38 & later BN44)
24.	604-25017 Adjuster, Hi Speed (38/44)
24a.	BN44/167 Adjuster, Hi Speed w/crossbar (38/44)
25.	BN38/344 Spring, Hi Speed
26.	BN38-39 Washer, Hi Speed (Alum)
27.	BN38/172 Washer, Low Speed (Alum)
28.	BN38/343 Spring, Low Speed
29.	604-26008 Adjuster, Low Speed (BN44 only)
29a.	BN38/477 Adjuster, Low Speed w/crossbar (BN38)
29b.	BN38/166 Adjuster, Low Speed w/crossbar (BN44)
30.	BN44/188 Cap
31.	786-35015-(sz) Needle Valve Assembly (Viton)
32.	VM15/285 Spring Clip, Needle Valve
33.	BN34/117-GG Plate, Needle Valve Retainer
34.	CW2-0307-G Screw with washer
35.	N100.606-(sz) Jet, Low Speed
36.	N102.221-(sz) Jet, High Speed
37.	BV15/121-05-GG Screw
38.	BN34/108-GG Plate, Valve
39.	BN44/164 Valve Body Assembly
40.	C5-0414-G Screw (2 pces)
41.	C6-0308-G Screw
42.	BN44/147 Cover (Stainless)
43.	MCWS-0512 Screw with washer (4) (Stainless)
44.	BN34/110 Spring

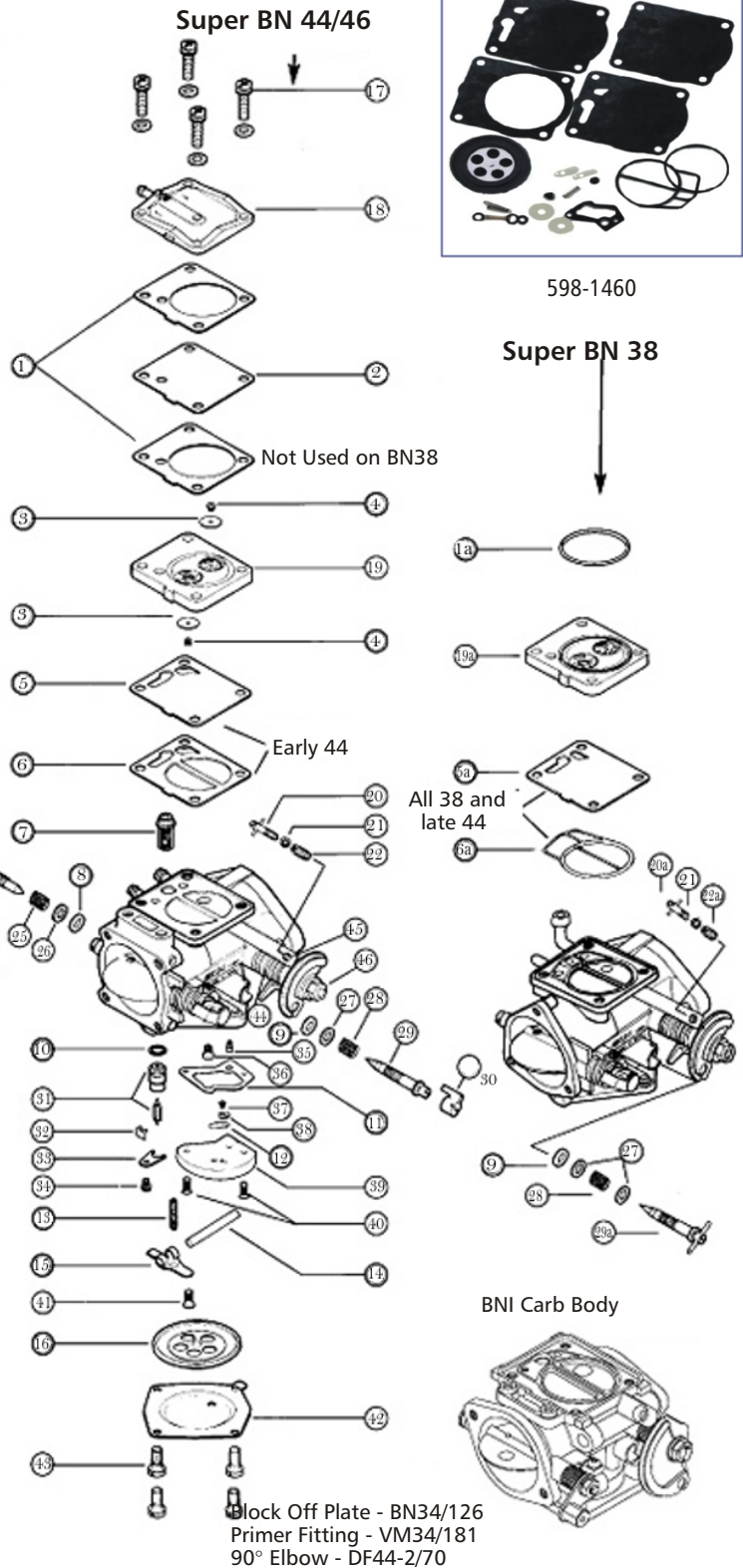

BN46I CARB REBUILD KIT

BNI Carb Rebuild Kit

MK-BN46i

- Kit includes items 1-18

Winderosa BNI Rebuild Kit 451469

598-1469

- Kit includes items 1-8, 9-14, 16 & 18

PART #	DESCRIPTION
1.	BN46I/13 Gasket, Pump
2.	BN46I/14 Diaphragm, Pump (Clear)
3.	616-73002 O'Ring
4.	BN46I/11 Check Valve (2)
5.	BN34/125 Grommet (2)
6.	BN46I/34 Diaphragm, Damper
7.	BN46I/15 Diaphragm, Damper (Clear)
8.	616-73003 O'Ring
9.	BN44/146 Filter, Fuel
10.	B30/305 O'Ring, Hi Speed (2)
11.	MD12/16 O'Ring, Low Speed
12.	KV/10 O'Ring, Needle Valve
13.	BN34/123 Gasket, Valve Body
14.	BN34/107 Check Valve (Clear)
15.	VM30/97 Pin, Arm
16.	730-03034 Spring, Arm (95 gr)
17.	BN38/534 Arm (Stainless)
18.	BN44/145 Diaphragm Assembly, Main



MK-BN46i



598-1469

BN46I Carburetor Replacement Parts

(Items 19-42 are NOT included in Rebuild Kit)

PART #	DESCRIPTION
19.	BN34/120-35 Screw with washers (4) (see note)
20.	BN46I/xx Cover, Pump
21.	BN46I/49 Body Assembly, Pump
22.	BN38I/40 Stop Screw, Idle
23.	BN38/39 Washer (Alum) (3)
24.	BN38/344 Spring (2)
25.	999-904-006 Cap, Hi Speed Adjuster
26.	604-25017 Adjuster, Hi Speed
27.	BN38/172 Washer (Alum) (2)
28.	BN38/343 Spring, Low Speed
29.	BN38/477 Adjuster, Low Speed
30.	N102.221-(sz) Jet, Hi Speed
31.	N100.606-(sz) Jet, Low Speed
32.	BV15/121-05-GG Screw
33.	BN34/108-GG Plate, Valve
34.	BN44/165 Valve Body Assembly
35.	C5=0414-G Screw (2)
36.	786-35018-(sz) Needle Valve Assembly
37.	BN34/117-GG Plate, Needle Valve Retainer
38.	CW2=0307-G Screw with washer
39.	C6=0308-G Screw
40.	BN44/147 Cover (Stainless)
41.	C25=0514 Screw (4) (see note)
42.	BN40I/22 Diaphragm, Accelerator Pump

Tightening Torque

Part #19: 4.5N/m (45 kg/cm)

Part #41: 3.5N/m (35 kg/cm)

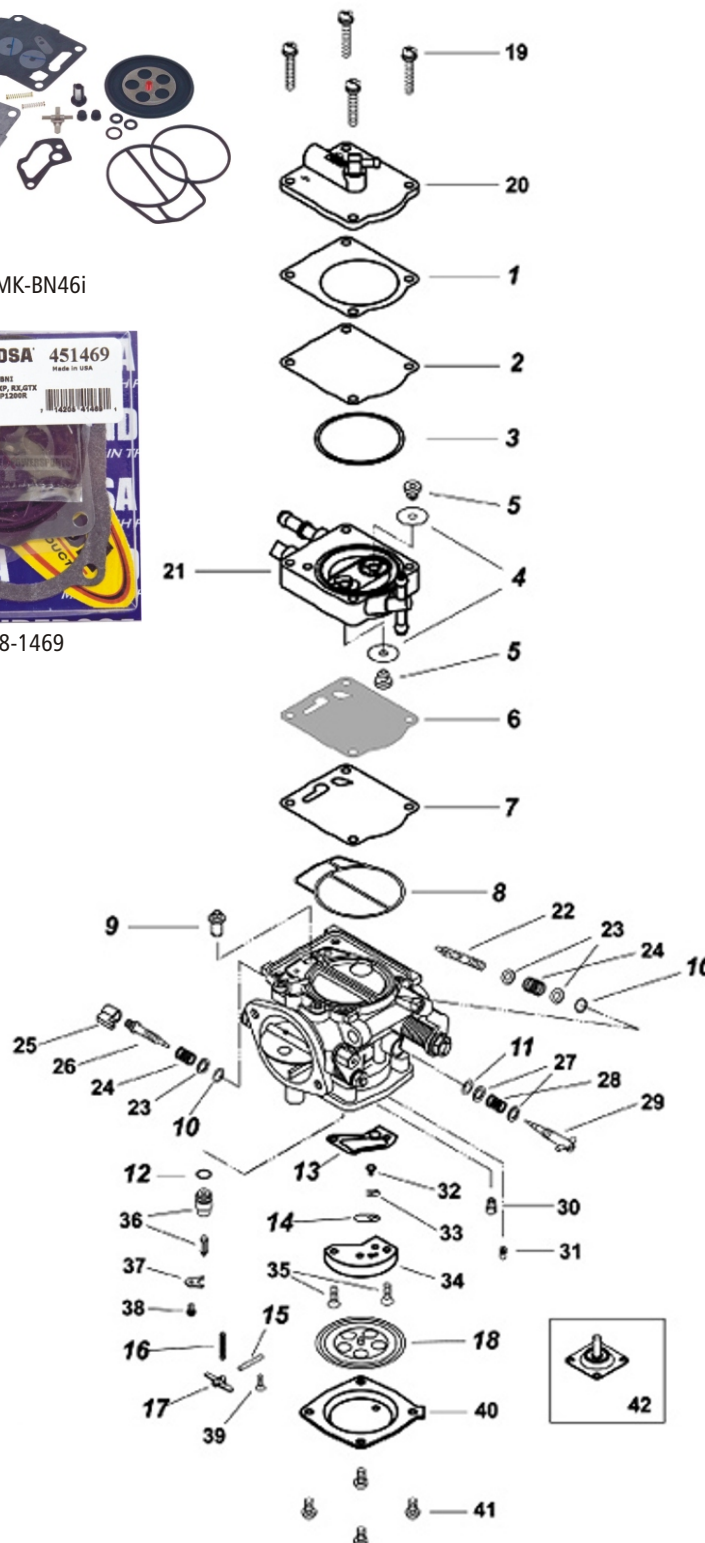



MIKUNI SNOWMOBILE CARBURETORS

Snowmobile Carburetors

Mikuni offers specially prepared carburetors designed to meet the unique demands of snowmobiles. Features are special throttle valve and needle valve designs better suited to colder, more dense air and constant throttle settings

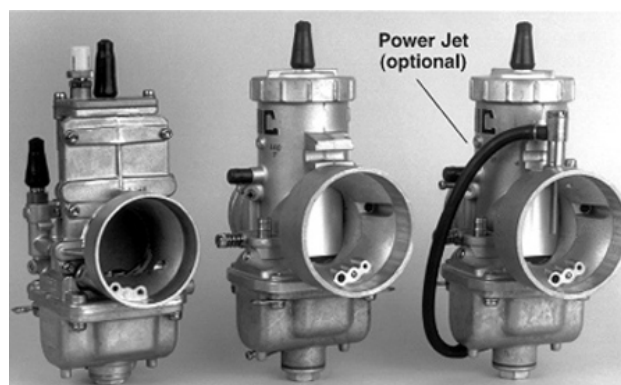

Carburetor Part #	Size (mm)	Main Jet	Pilot Jet	Needle Jet	Jet Needle	Throttle Valve	Main Air Jet	Needle Valve	Notes
VM30-164	30	4/042-270	VM22/210-35	VM34/05 Q-0	J8-6DH2	2	2.5 Body	1.5	Round Slide
VM32-282	32	4/042-280	VM22/210-35	VM34/05 Q-0	J8-6DH4	2.5	2.5 Body	1.5	Round Slide
VM34-389	34	4/042-330	VM22/210-30	VM34/05 Q-0	J8-6DH3	2.5	BS30/97-2.0	1.5	Round Slide
VM38-21	38	4/042-360	VM22/210-40	VM34/17 Q-0	J8-6DH3	VM38/24-2.5	2.5 Body	VM28/163-1.5	Round Slide
VM44-7	44	4/042-540	VM22/210-35	VM44/10 AA-5	J8-7DH2	VM40/02-1.5 Aluminum	BS30/97-0.7	VM28/163-1.5	Round Slide
TM38-102	38	4/042-340	VM22/210-25	785-24001 Q-2	J8-6FJ40	832-43011-4.0	2.5 Body	832-43011-1.5	TM Style Flatslide
TMX38-101	38	4/042-340	VM22/210-25	R-1 Fixed	J8-6EJ12-57	999-832-014-4.0	2.5 Body	786-36004-A	TMX Style Flatslide

Power Jet Kit

560-MK406

The Power Jet Kit is used in 2-stroke engine applications to improve mid-range throttle response and add additional fuel to wide open throttle running conditions especially with snowmobile clutches.

The kit can be installed easily on both Mikuni TM and VM Series carburetors.

- Fits 30 - 44 mm Carburetors
- Includes #80, 100, & 120 power jets



Mikuni Choke Cable Starter Kit

724-4751

Some carburetors come with cable operated starter systems and this kits allow for remote mounting of starter knob/lever. Kit includes:

- VM26/46 (Rubber Cap for Starter Plunger)
- M21/14 (Cable Adjuster)
- B30/247 (Cable Locknut)
- VM15/37 (Starter Plunger Fitting)
- VM32/69 (Starter Plunger Spring)
- VM15SC4/85 (Starter Plunger)



TUNING/JETTING COMPONENTS

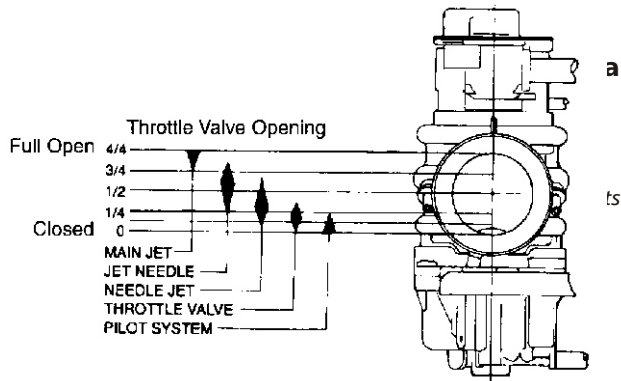

Parts - In Relation to the Throttle Valve Opening

MAIN JETS

Large Hex

TCI PART# 4/042 - (Jet Size)

Fits VM and TM Series

Jets are pre-packaged in bags of 4 but price is based on single jet. Please order Large Hex Main Jets in multiples of 4.

- 6 mm hex width, 5 mm thread diameter

Available Jet Sizes:

- 50 - 245 (increments of 5)
- 250 - 500 (increments of 10)
- 500 - 640 (increments of 20)
- 650, 660, 680, 700, 710, 720

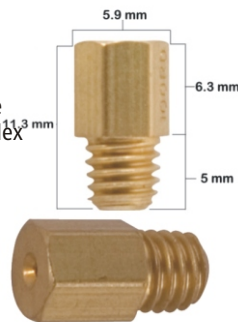

Small Hex

TCI PART#M10/14 - (Jet Size)

- Length 8 mm, 6 mm O.D.

Available Jet Sizes:

- 40 - 200 (increments of 5)

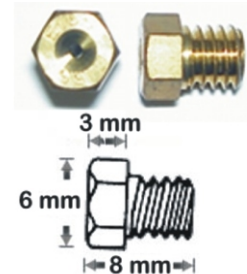

Large Round

TCI PART#N100/604 - Jet Size

Fits RS and HS Series

- Length 9 mm, 8 mm O.D.

Available Jet Sizes:

- 50 - 200 (increments of 2.5)
- 205 - 210 (increments of 5)
- 225 - 240 (increments of 10)

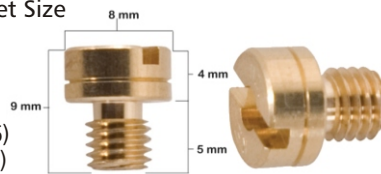

Small Round

TCI PART#N102.221 - Jet Size

Fits SBN Series

- Length 9 mm, 6 mm O.D.

Available Jet Sizes:

- 30 - 250 (increments of 2.5)

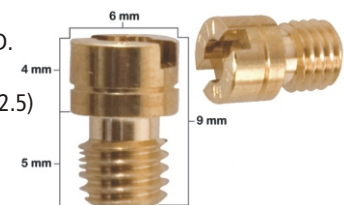

Large Thread

TCI PART#VM11/22 - Jet Size

- Length 8 mm, 10.5 mm O.D.

- Available Jet Sizes:

- 50 - 180 (increments of 5)

- [Special Order](#)

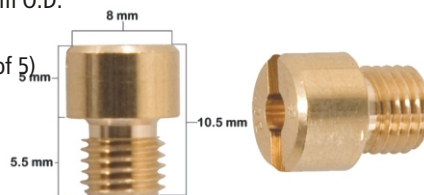

Press - In

TCI PART#N208.099 - Jet Size

Press in OEM Applications

- Length 9 mm, 6 mm O.D.

Available Jet Sizes:

- 115 thru 150 (increments of 5)

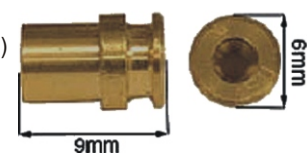



PILOT JETS

- Controls starting, idling and low speed operation until approximately ¼ throttle.

Fits all VM, TM, TMX Carburetors

TCI PART# VM22/210 - Jet Size

- Length 14 mm, 4 mm O.D.

Available Jet Sizes:

10 - 40 (increments of 2.5)

45 - 110 (increments of 5)

100 - 140 (Increments of 10)

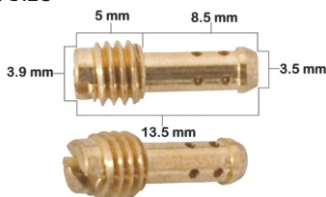

Fits all RS & HSR Carburetors and late model Suzuki RM 125/250

TCI PART# VM28/486 - Jet Size

- Length 28 mm, 5 mm O.D., 2 mm I.D.

- Thread 4 mm x 0.70 mm

Available Jet Sizes:

10 - 70 (increments of 2.5)



OEM for TMX, BSR Rhino CR, RM, YZ, KX

TCI PART# N224.103 - Jet Size

- Length 28 mm

- 5 mm O.D.

- 2.5 mm I.D.

- Has groove above thread area

Available Jet Sizes:

10 - 70 (increments of 2.5)

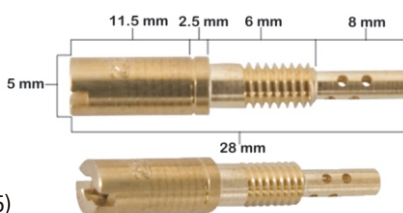

OEM Non-Bleed Type

Non bleed OEM Applications

TCI PART# N151.067 - Jet Size

- Length 14 mm, 4 mm O.D.

Available Jet Sizes:

30 - 60 (Increments of 2.5)



Bleed Type

TCI PART# BS30/96 - Jet Size

- Length 14 mm, 4 mm O.D.

Available Jet Sizes:

30 - 60 (increments of 2.5)

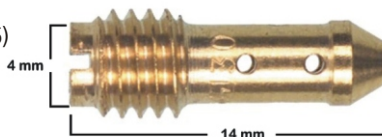

B-Type Butterfly Carbs

TCI PART# N101.043 - Jet Size

- Length 16 mm, 6.5 mm O.D.

Jet Size: (Increments)

30 - 100 (increments of 2.5)

105 - 160 (increments of 0.5)

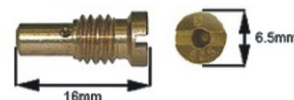

Super BN

TCI PART# N100.606 - Jet Size

- Length 6.5 mm, 4 mm O.D.

- 4 mm thread

Available Jet Sizes:

50 - 150 (increments of 2.5)

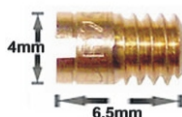

OEM Carbs, Banshee

TCI PART# M28/1001 - Jet Size

- Banshee OEM, OEM applications

- Length 5.5 mm

- 4 mm O.D.

Available Jet Sizes:

15 - 70 (increments of 2.5)

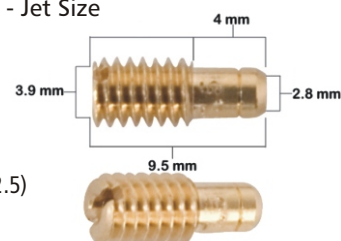

AIR JETS / STARTER JETS

AIR JET

TCI PART# BS30/97 - Jet Size

- Length 7.5 mm

- Thread 4 mm x 0.70 mm

- A fine tuning component in regulating air-fuel mixture

- Meters air flow to the needle jet

- For most Mikunis

Available Jet Sizes:

.5 thru 2.0 (increments of 0.10)



STARTER JET

TCI PART# VM17/1002 - Jet Size

- Controls enricher on TM carburetors

- Length 6 mm, 4 mm O.D.

Available Jet Sizes:

20 - 120 and 1.0, 1.5, 2.0



NEEDLE JETS

Needle Jets (a.k.a. Nozzles, Emulsion Tubes)

- Main fuel passage together with the needle controlling ¼ to ¾ throttle range.

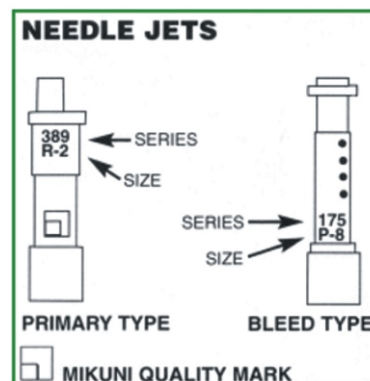

Jet Series	Carburetor Application	Type	Part #	Available Needle Jet Sizes	
				Leaner	Richer
	Round Slide Body		(990-793-004 from P-0 up)	P - 0, 2, 4, 5, 6, 8, 9; Q - 0, 1, 2, 3, 4, 5, 6, 7, 8; R - 0, 1, 2, 3, 4, 5, 6, 7, 8, 9	
166	VM38 Round Slide Body	Primary	VM34/17 (990-793-003 from P-0 up)	N - 6; O - 0, 2, 4, 5, 6, 8; P - 0, 2, 4, 5, 6, 8; Q - 0, 2, 4, 5, 6, 8; R - 0, 2, 4, 5, 6, 8	
480	VM38 (Same 166 OEM) OEM Round Slide	Primary	785-23005	N - 0, 6, 8; O - 0, 2, 3, 4, 5, 6, 8, 9; P - 0, 1, 2, 4, 5, 6, 7, 8; Q - 0, 1, 2, 3, 4, 5, 6, 7, 8, 9; R - 0, 1, 2, 4, 5, 8	
169	VM28 - VM30 TM28 Flat Slide	Primary	VM30/38	N - 2, 4, 6, 8; O - 0, 2, 4, 5, 6, 8; P - 0, 2, 4, 5, 6, 8; Q - 0, 2, 4, 5, 6, 8	
	VM30 - 36				
176	VM30 - 36 Round Slide Body	Bleed	VM32/19	O - 0, 2, 4, 6, 8; P - 2, 4, 6, 8	
182	VM26 Round Slide Body	Primary	VM28/86	N - 0, 4, 6; O - 0, 2, 4, 6, 8; P - 0, 2, 4, 6, 8; Q - 0, 2	
224	VM40 - VM44 Round Slide Body	Primary	VM44/10	Z - 0, 2, 4, 5, 6, 7, 8, 9; AA - 0, 1, 2, 3, 4, 5, 6, 7, 8, 9; BB - 0, 1, 2, 3, 4, 5, 6, 7, 8, 9; CC - 0, 5,	
247	Yamaha OEM	Primary	VM38/41	N - 6, 8; O - 0, 2, 4, 6, 8; P - 0, 2, 4, 6, 8; Q - 0, 2, 4, 5, 6, 8; R - 0, 2, 4, 6, 8	
261	VM29 - VM33	Bleed	VM29/16	O - 0, 2, 4, 6, 8; P - 0, 2, 4, 6, 8	
389	TM32 - TM38 Flat Slide	Primary	785-24001	O - 0, 2, 4, 6, 8; P - 0, 2, 4, 5, 6, 8;	
568	RS34 - RS40 HS40 - TM36	Non-Bleed	784-13002	Q - 6, 8; P - 0, 2, 4, 5, 6, 8; Y - 0, 2, 4, 5, 6, 8; Z - 0, 2, 4, 5, 6; AA - 0; BB - 0	
	TMX OEM Series HS40 - TM36			Z - 0, 2, 4, 5, 6; AA - 0; BB - 0	
723	HSR42 - HSR48 Roller Flat Slide	Non-Bleed	784-430000	Y - 2, 4, 6, 8; Z - 0	
633	TMX OEM Series Flat Slide Body		784-13005	S - 4, 7, 8; T - 0	



NEEDLE JETS

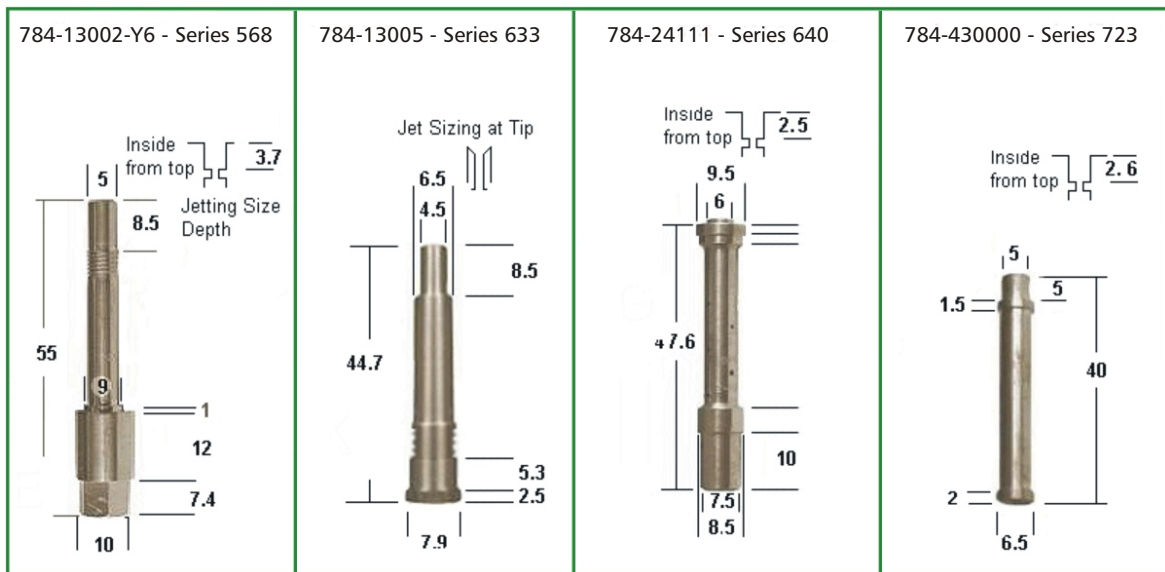
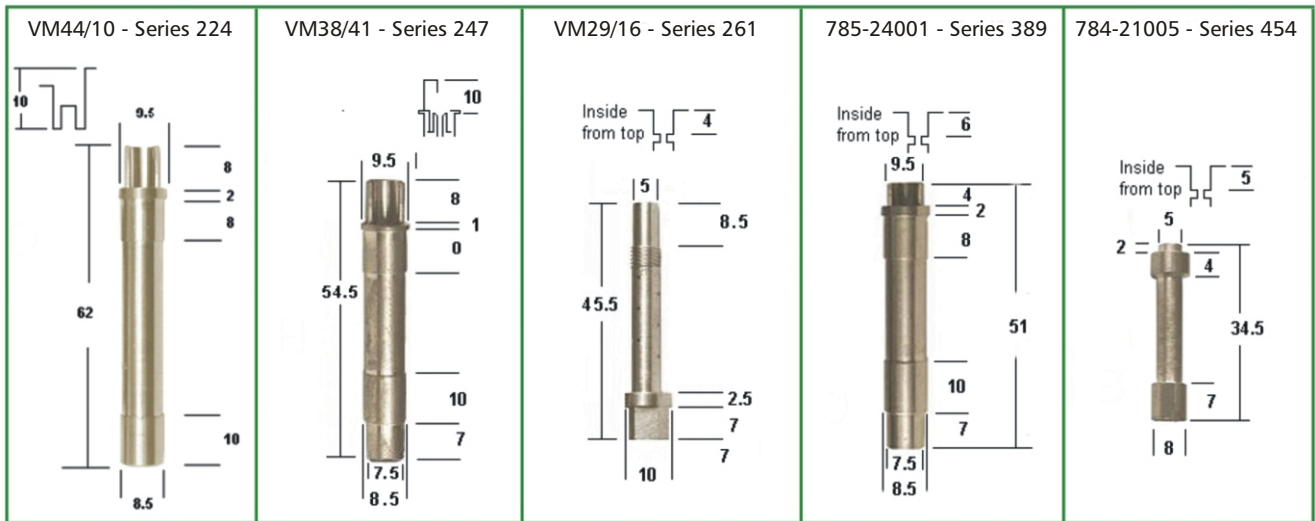
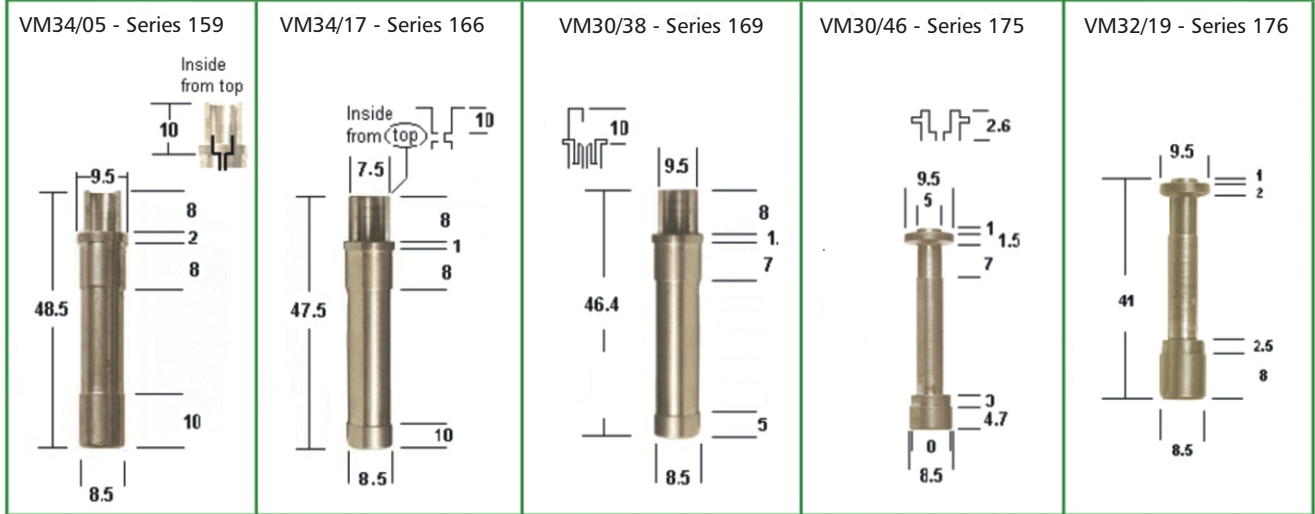



NEEDLES SEAT GASKETS

PART #	DESCRIPTION	STYLE
VM26/23	Gasket - 8 mm Needle & Seat Assembly	Threaded
VM26/25	Gasket - 9 mm Needle & Seat Assembly	Threaded
B34/52-0.5	Gasket - 0.5 x 10 mm Needle & Seat Assembly	Threaded
B34/52-0.8	Gasket - 0.8 x 10 mm Needle & Seat Assembly	Threaded
KV/10	O'Ring for Needle & Seat Assembly	Push In

NEEDLES & SEAT ASSEMBLIES (AKA NEEDLE VALVE)

- determines and regulates the rate of flow of fuel from the gas tank to the float bowl assembly.
- The larger the size the greater the flow; 1.5 is the suggested size for fuel pumps.

THREADED - includes Needle Valve and Needle Seats (washer **NOT** included)

PUSH IN - includes Needle Valve, Needle Seat, O-Ring, and Needle Valve Clip when applicable.
(**NO** O-ring on RS series Needle Valve)

Carburetor	Standard Metal Tip				Viton Tip				O/Ring/ Gasket
	Pic	Part #	Available Sizes	Style	Part #	Pic	Available Sizes	Style	
BN34, BN38, BN44 Watercraft	A	VM26/26-xx	1.0, 1.2, 1.5, 1.8, 2.0, 2.3, 2.5, 2.8	Threaded	786-15005-xx w/ float clip	B	1.5, 2.0, 2.5	Threaded	VM26/25
		560-7025	VM26/26-1.5 (from Taiwan)	Threaded					
1990 Sea Doo, BN38/44 Rnd Watercraft Carb					786-15008-xx	B	1.5, 2.0, 2.3, 2.5	Solid	
Super BN38-BN46 and Hign Perf. BNi34-BNi46					786-35015-xx	D	1.0, 1.5, 1.8, 2.0, 2.3, 2.5	Push-In	
Hign Perf. BNi46					786-35018-xx	O	1.2, 1.5, 1.8, 2.0, 2.3, 2.5	Push-In	
HS40					990-786-044	E	3.8	Push-In	
HSR42, HSR45					786-27001-xx	F	2.3 (Smaller), 4.2 (Std), 3.5 (Pressure Feed Only)	Push-In	
HSR 48					786-27002-1A	F	4.5	Push-In	
RS34/36/38/40	N	N149.040-xx	2.0, 2.5, 2.8 (2.8 is std)						KV/10
TM28 Flatslide	J	VM24/557-xx	1.5, 2.0, 2.5	Push-In					
TM32/34/36/38 Flatslide	C	786-46001-xx	1.2, 1.5, 1.8, 2.0, 3.0, 3.3, 3.5	Push-In	Dyna Flow Viton Tip		594-12723 (size is 1.5) 594-12722 (size is 2.0)		
TM33-8012 Snowmobile	OEM				N133.200-xx	M	1.2, 1.5, 1.8, 2.0, 2.3		
TM36 Flatslide					786-36011-3.3	P	3.3	Push-In	
TMX35/38	G	786-36004-xx	3.5						
TM38-101 TMX Style	G	786-36004-A	1.8						
TM40-6					990-786-044	E	3.8	Push-In	
VM16-519	H	VM34/39-xx	1.5, 2.5, 3.0, 3.3, 3.5	Threaded					
VM18-144/VM20-273	K	VM15/172-xx	1.2, 1.5, 1.8, 2.0	Threaded					
VM(TM)28-418 Flatslide (& Banshee)	L	VM24/557-xx	1.5, 2.0, 2.5	Push-In					
VM29/33 Smoothbore Carb	Q	N122.032-xx	2.5, 2.8	Threaded					
VM24 to 38	A	VM26/26-xx	1.0, 1.2, 1.5, 1.8, 2.0, 2.3, 2.5, 2.8	Threaded	VM26/185	A	1.5, 2.0, 2.5	Threaded	VM26/25
		560-7025	VM26/26-1.5 (from Taiwan)	Threaded					
VM30 to 44	H	VM34/39-xx	1.5, 2.5, 3.0, 3.3, 3.5	Threaded	VM28/511-xx	H	1.5, 1.8, 2.0, 2.5	Threaded	B34/52-xx 0.5 or 0.8
VM30 to 44	I	VM38/11-xx	3.3, 3.5 (6 hole metal tip) (3.5 Yamaha OE 24X-14107-35-00)						B34/52-xx 0.5 or 0.8
VM38-21, VM44-7	J	VM28/163-xx	1.0, 1.2, 1.5, 1.8, 2.0, 2.5, 3.0	Threaded	VM28/511-xx	H	1.5, 1.8, 2.0, 2.5	Threaded	B34/52-xx 0.5 or 0.8
		560-7026	VM28/163-1.5 (from Taiwan)	Threaded					

Sizes reference in red are special order See following page for Needle and Seat Assembly pictures with dimensions



NEEDLES & SEAT ASSEMBLIES (AKA NEEDLE VALVE)

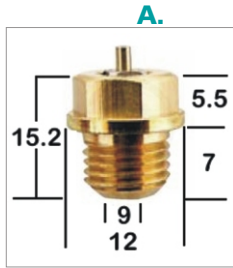

VM26/26-xx
Metal Tip

VM26/185-xx
Vitron Tip
Washer for Needle & Seat
VM26/25

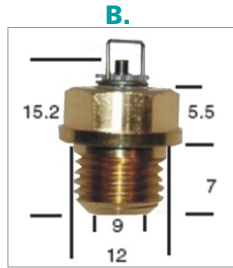

786-15005-xx
Metal Tip

786-15008-xx Vitron Tip
(special order)
Solid Needle stem - no
spring
Washer for Needle & Seat
VM26/25

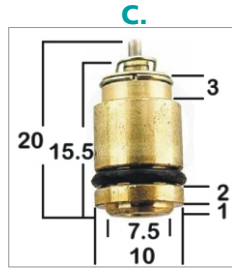

786-46001-xx
Metal Tip

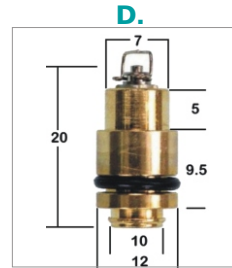

786-35015-xx
Vitron Tip

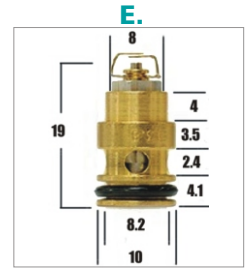

990-786-044-3.8
Vitron Tip

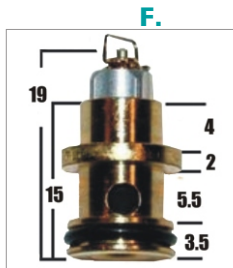

786-27001-xx
VitronTip
&

786-27002-1A-4.5
(special order)
Vitron Tip
O'ring for Needle & Seat
KV/10



786-36004-3.5
&
783-36004-A-1.8

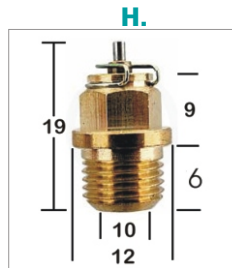

VM 34/39-xx
Metal Tip

VM28/511-xx
Vitron Tip
Washer for Needle & Seat
B34/52-xx

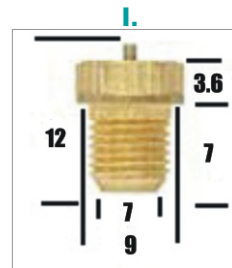

VM15/172-xx
Metal Tip



VM24/557-xx
Metal Tip

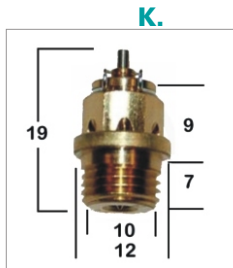

VM38/11-xx
6 hole
Metal Tip

Washer for Needle & Seat
B34/52-xx

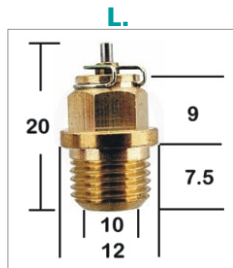

VM 28/163-xx
Metal Tip

Washer for Needle & Seat
B34/52-xx

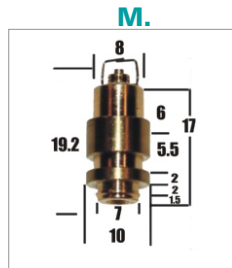

N133.200-xx
Vitron Tip

O'ring for Needle & Seat
KV/10

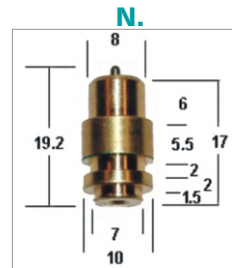

N149.040-xx
Metal Tip

Needs O-Ring KV/10

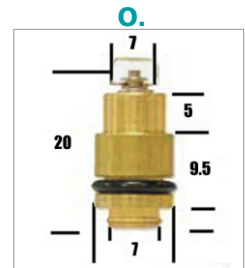

786-35018-xx
(special order)
Vitron Tip

O'ring for Needle & Seat
KV/10



786-36011-xx
(special order)
Vitron Tip



N122.032-xx
Metal Tip



TUNING AND JETTING COMPONENTS

Needles (a.k.a. Jet Needle)

The Jet Needle controls the fuel mixture in the midrange (1/4 - 3/4) throttle position. The taper of the needle determines the amount of fuel. For example, the thinner the diameter of the needle, the more fuel will be drawn. The thicker the diameter of the needle. The less fuel can be drawn.

Two Types of Needles

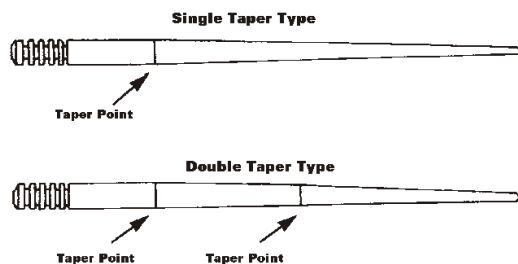

D1 through D-5 indicates diameter (mm) at each point

	A	B	D-1	D-2	D-3	D-4	D-5
4DG6	50.3	24.0	2.518	2.518	2.405	2.119	1.850
4E1	50.3	28.0	2.515	2.515	2.345	2.127	1.924
4F10	50.2	24.5	2.513	2.513	2.385	2.135	1.877
4L6	50.3	24.5	2.515	2.515	2.178	1.660	1.190

D1 through D-6 indicates diameter (mm) at each point

	A	B	C	D-1	D-2	D-3	D-4	D-5	D-6
5D5	57.6	30.0		2.513	2.513	2.513	2.366	2.205	
5D120	59.1	28.2		2.520	2.520	2.479	2.311	1.980	
5DH21	52.3	30.1	16.5	2.515	2.470	2.465	2.328	2.024	
5DP2	60.3	32.4		2.515	2.512	2.513	2.418	2.067	1.418
5DP7	57.6	26.4		2.512	2.512	2.440	2.259	1.580	
5EJ11	60.3	28.5		2.515	2.515	2.515	2.241	1.839	1.420
5F3	58.0	27.4		2.519	2.519	2.419	2.135	1.863	
5FJ9	59.2	35.0		2.517	2.517	2.517	2.364	2.021	
5FL7	58.0	28.0		2.518	2.518	2.440	2.170	1.735	
5FL11	60.3	28.2		2.518	2.518	2.438	2.175	1.740	1.256
5FL14	58.0	28.0		2.520	2.520	2.440	2.170	1.735	
5J6	58.0	27.5		2.518	2.518	2.340	1.890	1.450	
5J9	58.0	27.0		2.522	2.520	2.432	1.996	1.505	
5L1	58.0	27.0		2.518	2.518	2.330	1.811	1.297	

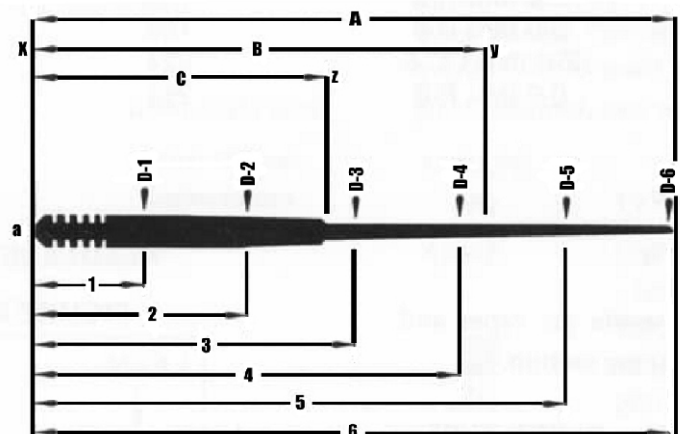

Series Type	Application
#4	All 18mm Carburetors, 22 mm and 24 mm Flange
#5	26 mm - 32 mm Spigot, 28 mm - 34 mm Flange
#6	30 mm - 38 mm Spigot
#7	40 mm and 44 mm Spigot
#8	HSR42/45 Carburetors
#9	RS and HS Carburetors

D1 through D-6 indicates diameter (mm) at each point

	A	B	C	D-1	D-2	D-3	D-4	D-5	D-6
6CF1	61.5	29.5		2.512	2.512	2.429	2.240	1.974	1.710
6DH2	62.3	28.0		2.511	2.511	2.466	2.295	2.000	1.660
6DH3	62.3	22.0		2.512	2.512	2.458	2.286	1.948	1.607
6DH4	62.3	25.5		2.520	2.520	2.440	2.258	1.915	1.575
6DH7	62.2	28.5		2.516	2.516	2.505	2.316	2.009	1.688
6DH8	62.2	20.3		2.538	2.538	2.436	2.208	1.827	1.497
6DJ30	64.7	26.3		2.510	2.510	2.450	2.090	1.660	1.240
6DP1	62.3	28.9		2.511	2.511	2.476	2.312	1.748	1.075
6DP10	62.4	26.5		2.510	2.510	2.440	2.260	1.560	.890
6DP17	62.3	32.1		2.518	2.518	2.518	2.372	1.834	1.141
6F3	60.5	34.2		2.512	2.512	2.512	2.313	2.050	
6F4	62.3	32.0	19.4	2.515	2.442	2.436	2.206	1.939	1.678
6F5	62.3	38.1	19.0	2.515	2.456	2.454	2.364	2.098	1.840
6F8	62.3	34.0	21.5	2.512	2.512	2.386	2.214	1.945	1.688
6F9	62.3	28.9		2.516	2.516	2.475	2.210	1.949	1.678
6F13	64.2	32.8		2.500	2.460	2.460	2.240	1.970	1.700
6F15	62.2	19.8		2.535	2.538	2.461	2.208	1.979	1.649
6F16	64.6	31.2	18.4	2.520	2.404	2.400	2.201	1.941	1.679
6FJ6	62.3	35.2		2.505	2.505	2.505	2.376	2.040	1.606
6FL14	62.1	26.7		2.538	2.538	2.538	2.233	1.649	1.218
6J1	64.0	36.2		2.517	2.517	2.517	2.339	1.919	1.495
6L1	62.3	37.0		2.512	2.512	2.512	2.335	1.826	1.313
6N1	62.3	37.0		2.514	2.514	2.514	2.278	1.672	1.058

D1 through D-7 indicates diameter (mm) at each point

	A	B	D-1	D-2	D-3	D-4	D-5	D-6	D-7
7DH2	75.3	31.6	2.99	2.99	2.99	2.84	2.66	2.27	1.92
7DH3	72.5	28.1	2.98	2.98	2.96	2.80	2.47	2.11	1.76
7DH5	72.2	27.4	2.98	2.98	2.94	2.78	2.44	2.08	1.72
7F6	72.3	29.0	3.00	3.00	2.95	2.68	2.41	2.14	1.87
7F7	72.3	33.1	2.99	2.99	2.99	2.80	2.54	2.28	2.02

A = Needle Length (mm)

B = Length between point (x) and the taper point (y)

C = Length between point (x) and the pronounced taper point (z)

- 1 = 10mm D-1, D-2, D-3, D-4
- 2 = 20mm D-5, D-6 are the
- 3 = 30mm actual taper
- 4 = 50mm deameters at those
- 5 = 50mm given points in
- 6 = 60mm millimeters



TUNING AND JETTING COMPONENTS

Needles (a.k.a. Jet Needle) con't.



Jet Needle Number	Applications	Needle Diameter Before Taper (mm)	Air Fuel Ratio
J8-6FJ41	TM38 Flatslide	2.522	Leanest ↕ Richest
J8-6FM46		2.522	
J8-6FJ40		2.522	
J8-6DP04		2.515	
J8-6EJ12-60	Early TMX38 Flatslide	2.60	Leanest ↕ Richest
J8-6EJ12-59		2.59	
J8-6EJ12-58		2.58	
J8-6EJ12-57		2.57	
J8-6EJ12-56		2.56	
J8-6EJ12-55		2.55	
J8-6EJ12-54		2.54	
J8-6EJ12-53		2.53	
J8-6EN11-58	Early TMX35 Flatslide	2.58	Leanest ↕ Richest
J8-6EN11-57		2.57	
J8-6EN11-56		2.56	
J8-6EN11-55		2.55	
J8-6EN11-54		2.54	
J8-6EN11-53		2.53	
J8-6EN11-52		2.52	
J8-9DZH01 (Std)		RS34 - 36	
J8-9DZH03	Smoothbore	2.49	
J8-9DZH04		2.48	
J8-9CHY03 (Std)	RS38-40	2.99	Leanest ↕ Richest
J8-9CHY05	Smoothbore	2.95	
J8-9CHY06		2.97	
J8-8DDY01-98	HSR42	2.98	Leanest ↕ Richest
J8-8DDY01-97 (Std)		2.97	
J8-8DDY01-96		2.96	
J8-8DDY01-95		2.95	
J8-8CFY02-98	HSR45	2.98	Leanest ↕
J8-8CFY02-97 (Std)		2.97	

CHOKE SYSTEMS

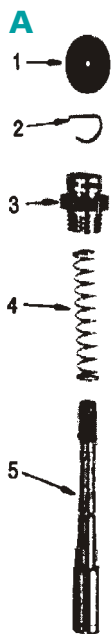

A. Pull-Up Type

DESCRIPTION	PART #	CARBURETOR
1. Rubber Cap, Starter	VM20/455	36-44 Spigot
2. Set Clip, Starter Plunger	VM14SC11/99	36-44 Spigot
3. Cap, Starter Plunger	VM20/300	36-44 Spigot
4. Spring, Starter Plunger	VM14SC11/89	36-44 Spigot
5. Starter plunger	VM38/06	36-44 Spigot

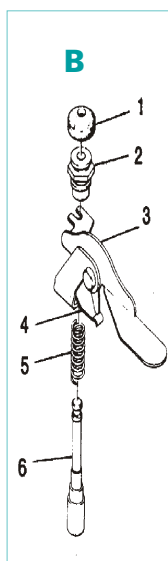

B. Lever Type

DESCRIPTION	PART #	CARBURETOR
1. Rubber Cap, Starter	VM20/455	All
2. Cap, Starter Plunger	VM20/456	All
3. Lever, Starter	VM28/135.so	26
	VM28/497.so	28
	VM28/154.so	30 - 34
	VM32/53	36 - 38
	VM36/58.so	40 - 44
4. Spring Plate, Starter Level	VM26/09C	26 - 28
	VM32/17	30 - 44
5. Spring, Starter plunger	VM16/42	All
6. Starter Plunger	VM15/62	24 - 28
	VM18/144	30 - 44

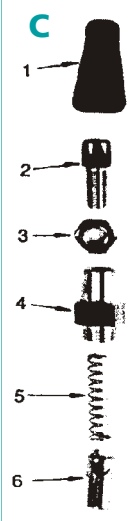

C. Cable Type

- Complete Kit Available on page 24 - (part # 724-4751)
- Snowmobile carburetors come with cable operated starter systems

DESCRIPTION	PART #	CARBURETOR
1. Rubber Cap, Starter	VM26/46	30 - 44
2. Cable Adjuster	M18F/43A	30 - 44
3. Adjusting Lock Nut	B30/247	30 - 44
4. Cap, Starter Plunger	VM15/37	30 - 44
5. Spring, Starter Plunger	VM14SC11/89	30 - 44
6. Starter Plunger	VM15SC4/85	30 - 44



MIKUNI FLOAT BOWL GASKETS

Float Bowl Gaskets

FITS CARBURETORS

VM26 - VM34
 VM28 - VM34
 VM28-418 (TM 28)
 VM30
 VM33 Smoothbore
 VM34
 VM30 - VM34 Spigot Type
 VM36 - VM44
 TM36 - TM38
 TMX35 & TMX38

PART

VM30/103
 VM28/129
 VM26/228
 VM30/172
 VM30/257
 999-631-010 (VM34/71)
 999-631-011 (VM34/30)
 VM36/20
 VM34/374
 TM38/52



VM26/228



VM28/129



VM30/103



VM30/172



VM30/257



VM34/374



VM36/20



999-631-010 (VM34/71)

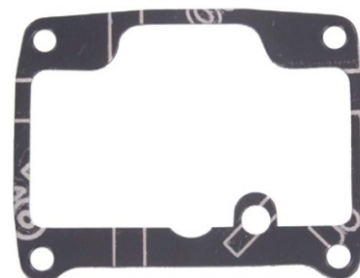

999-631-011 (VM34/30)

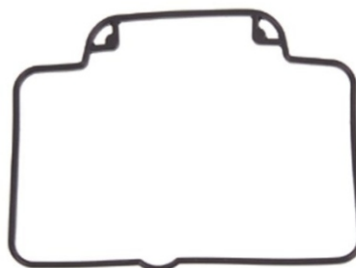

TM38/52

THROTTLE VALVES

Throttle Valve (a.k.a. Cutaway or Slide)

- Affects the air-fuel mixture from 1/8 to 1/2.
- The larger the cutaway (size), the more air flows, which causes a leaner condition.

To determine a left hand or right hand throttle valve you must look at it from the intake side (cutaway facing you) to see what side your idle adjustment is on. if it is on the left, it is a left-hand throttle valve and if it is on the right side it is a right-hand throttle valve.

Brass slides are chrome plated

Aluminum slides are anodized, xylan or nickel-plated.



Fits 30 - 44 Spigot
Carburetor



999-832-014
TMX 35, 38

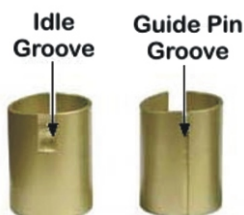

Part #	Carburetor Application	Slide Material	Idle Groove Position	Guide Pin Groove Width	Cut-W-Way Available
VM28/56	26-28 Spigot	Brass	Left	2.05 mm	1.5, 2.0
VM30/176	30 /small Body	Brass	Left	2.05 mm	1.0 thru 3.5
VM32/65	30, 32, 34 Spigot	Brass	Right	2.60 mm	1.5 thru 3.5
VM34/110	30, 32, 34 Spigot	Brass	Left	2.60 mm	1.0 thru 3.5
VM36/36	36 Spigot	Brass	Left	3.05 mm	1.5 thru 3.5
VM36/39	36 Spigot	Brass	Right	3.05 mm	3.0, 3.5
VM38/24	38 Spigot	Brass	Right	3.05 mm	1.0 thru 3.5
VM38/52	38 Spigot	Brass	Left	3.05 mm	1.5 thru 3.5
VM40/02	40, 44 Spigot	Aluminum	Left	3.05 mm	0.5 thru 4.0
VM44/23	40, 44 Spigot	Brass	Left	3.05 mm	1.5 thru 4.0
832-39012	TM32-34	Aluminum	Left		4.0
832-41018	TMX38	Brass	Left		5.0
832-43002	TM36, 38-1,3	Aluminum	Left		1.5 thru 5.0
832-43011	TM38-85,86	Aluminum	Left		2.5 thru 4.5
999-832-014	TMX35, 38	Aluminum	Left		2.5 thru 6.0
999-832-017-1H	TMS38, 125	Aluminum	Left		None



Keihin Main Jet Carrier

560-1878

Holds 3 Slide Needles and 20 Main Jets

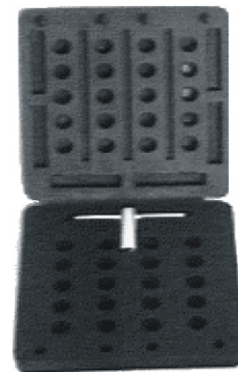

MAIN JETS FOR KEIHIN

High precision brass jets that are made in the UK. All jets are flow calibrated and extremely accurate in terms of fuel flow rate as stamped.

TCI Part# 31-9(Jet Size)

- Length 8 mm, O.D. 7 mm

Jet Size: increments 165 thru 220 (5) (ie. 165, 170, 175, 180, 185)

Keihin# N424-27

Applications: **Main Jet for CVH (American V-twin)**



TCI Part# 31-3(Jet Size)

- Thread 5.0 mm x 0.80 mm
- Length 8 mm, O.D. 6 mm

Jet Size: increments 75 thru 175 (2,3,3,2) (ie. 100, 102, 105, 108, 110)

Keihin# N424-36

Applications: **Starter Jet for FCR-MX, Main Air Jet for FCR's.**

Main Jet for: CVK, CDK, CDKII 38 & 42 Watercraft Carbs,

Honda VB, VD, VE series carburetors,

CB750 Nighthawk (91-04), CB750A (76-78), CB750C (80-82), CB750F Super Sport (79-82),

CB750K (77-82), CB750 SC Nighthawk, VFR750F Interceptor (1986), VFR750R (90-95),

CBX1047cc (79-82GL1100/A/I Goldwing (80-83)

Kawasaki -OEM Jet-S), ki with CDK carbs, ATV, Street and Offroad models with **CVK**, and

ATV's with **CVKR-D (V-Twin ATV)**

Suzuki ATV Twin Peaks 700 with **CVKR-D (V-Twin)** .

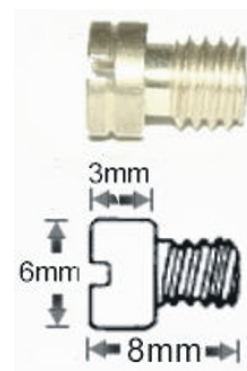

TCI Part# 31-4(Jet Size)

- Thread 5 mm x 0.8 mm
- Length 16.5 mm

Jet Size: increments 100 thru 220 (2,3,3,2) (ie. 100, 102, 105, 108, 110)

Keihin# 99101-357

Applications: **Aftermarket FCR, CRS plus OEM ...**

Honda PD (Dual Purpose PE-34-38PE (motocross), PJ, PD, VG (motocross) (STV)

Kawasaki PWK (motocross)

Harley Davidson BD Screamin' Eagle

Yamaha BD (Snowmobile), PWM (motocross)

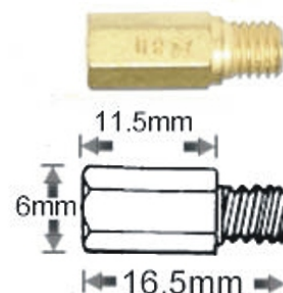

SLOW JETS FOR KEIHIN

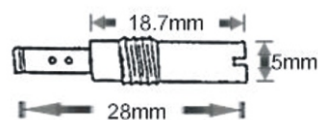

TCI Part# 31-2(Jet Size)

- Thread 6 mm x 0.75 mm
- Length 28 mm

Jet Size: increments 35 thru 70 (2,3,3,2) (ie. 040, 042, 045,048)

Keihin# N424-21

Applications: **OEM FCR-MX, Aftermarket CVK20**

PD22, PE20, 26, 28, 30mm, PJ34, 36, 38mm, PWM 34, 36, 38mm, PWK28, 33, 35, 38, 39mm, PWK36 Quad Vent, PWK 35, 38 Quad Vents/Air Strikers
Honda ATC200 (81-83), ATC250R (83-84), FL350R Odyssey (1985), CRF450R (02-05), TRX450R (2006), CR500R, CBR1000F Hurricane (87-88)

Kawasaki - KX125, KX250, KX500 with Keihin PWK carb

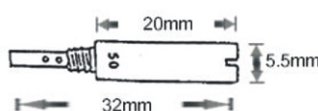

TCI Part# 31-1(Jet Size)

- Length 32 mm, O.D. 5.5 mm

Jet Size: increments 40 thru 70 (2,3,3,2) (ie. 040, 042, 045,048)

Keihin# N424-24

Applications: **CR Special (CRS)** 26 - 33mm & 35 - 39mm Carburetors

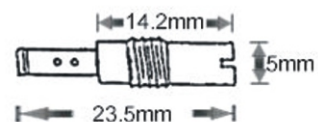

TCI Part# 31-5(Jet Size)

- Length 23.5 mm, O.D. 5 mm

Jet Size: increments 40 thru 70 (2,3,3,2) (ie. 040, 042, 045,048)

Keihin# N424-26

Applications: **PE Series - PE20, 26, 28, 30mm, and OEM...**

Some Honda VB Series using 99101-MA4 jets
Honda ATC250ES, ATC250SX, TRX250 (1985), Honda XR650L

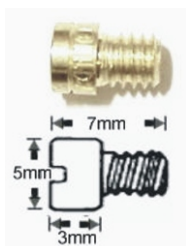

TCI Part# 31-6(Jet Size)

- Length 7 mm, O.D. 5 mm

Jet Size: increments 65 thru 95 (2,3,3,2) (ie. 070, 072, 075, 078)

Keihin# N424-35

Applications:

Pilot Jet - CDK, CDKII 38 & 42 PWC, Kawasaki OEM Jet-Ski.

Main Jet - PB16, PB18 (small ATV), PC18, PC20

Honda XR80, ATC70 (78-85), TRX70, TRX90

Kawasaki KLX110

Suzuki DR-Z110

Main Air Jet - KTM 950 Adventurer

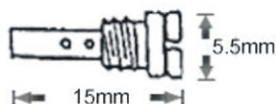

TCI Part# 31-7(Jet Size)

- Thread 4.5 mm x 0.75 mm
- Length 15 mm

Jet Size: increments 38 thru 68 (2,3,3,2) (ie. 040, 042, 045,048)

Keihin# N424-25

Applications: **Aftermarket FCR and OEM ...**

Arctic Cat ATV with CVK Carb

Harley Davidson BH (non CV Type), BD (Screamin' Eagle)

Kawasaki models with CVK and FCR carburetors (except VN700/750-1500 Vulcan with CVK)

Yamaha BD Snowmobile, YZF600R (95-07)



CARB MOUNTING FLANGES

- Most older snow machines that have common engines (Kolher, Xenoah, Kawasaki, CCW, etc) used standard Mikuni carbs or other carbs that can be switched to use Mikuni carbs.
- Use measurement chart to select correct flange.

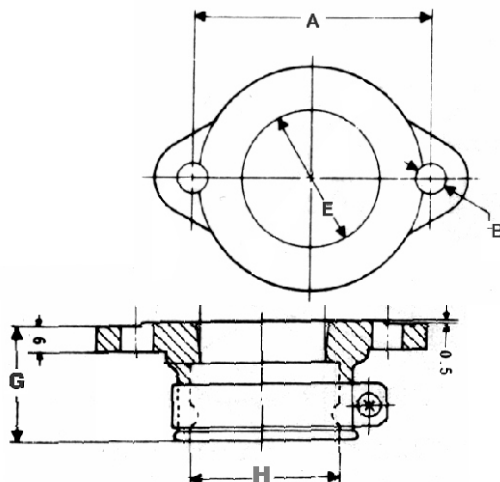

TCI Mikuni#	TCI SPI #	A = Engine Mount Bolt Hole	B = Bolt Hole Size	E = Inside ID	F = Carb Bore Size	G = Flange Throat Depth	H = Carb Spigot Diameter	Typical Carb Size
VM30/288	07-100-01	57.2 (HR)	8.5	31	30	23	37	VM26~28
	07-100-08	57.2 (HR)	8.5		30	40.5	37	VM26~28
	07-100-03	60	8.5		30	23	35	VM26
IVM28/200-1		60	8.5		30	28	35	VM26~28
IVM34/200-1	***	60	8.5		36	25	40	VM30~34
	07-100-05	60	8.5		39.5	44	39.5	VM30~34
IVM36/200-1 *	* 07-100-06	70	8.5		40	44	43	VM36~40
	07-100-02	74.6 (HD)	8.5	31	29.5	29	35	VM26~28
VM32/205	07-102-01 or 07-100-46 **	74.6 (HD)	8.5	35	34	32	40	VM30~34
IVM38/200-1 *	* 07-105-01	74.6 (HD)	8.5		40	28	43	VM36~40
	07-100-47	74.6	8.5	38	38	47	43	VM36-40
	07-106-08	74.6	9.5	38	39	44	41	VM36-40
	07-106-69	75.5	8.5	38	38	47	43	VM36-40
KHS-004 *	See * above	70-75	12x8.5		40	28	43	VM36~40
	07-100-07	74.6 (HD)	8.5		41.5	52	40	VM30~34
HS42/062-42		70-75	8.5		42	25	45	TM42
HS42/018-42		70-75	8.5		42	25	45	TM42
HS42/018-45		70-75	8.5		45	25	48	TM45
IVM40/200-1	07-100-15	74.6 (HD)	8.5	47	46	32	52	VM40~44
IVM44/200-1		84	8.5		46	24	52	VM40~44

* IVM36/200-1 and IVM38/200-1 supercede to KHS-004 with oval mounting bolt hole

**07-100-46 has separate o-ring

*** close substitute are 07-100-05 (longer throat)

FUEL PUMPS

Mikuni Pulse Fuel Pumps employ an engine's fluctuating engine crankcase pressure to pump fuel from a remote fuel tank to the engine's carburetor.

TCI Part#	# Of Outlets	Style	Mounting	Flow Rate(litre/hr)
DF44-211 (non-asbestos)	1 (Single)	Rectangle	Flush	14
DF52-176 (non-asbestos)	2 (Dual)	Round	Bracket	35
DF52-73	2 (Dual)	Round	Flush	35
DF52-92	3 (Triple)	Round	Flush	35
DF52-136	2 (Dual)	Square	Flush	31
598-1883	2 (Dual)	Square	Flush	70
DF62-702	2 (Dual)	Pentagon	Flush	65

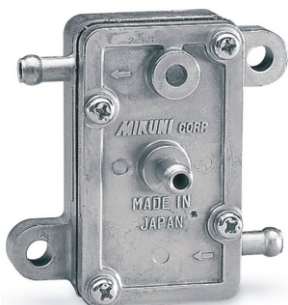

Single - Rectangular - Flush
DF44-211



Dual - Square - Flush
DF52-136



Dual - Round - Bracket
DF52-176

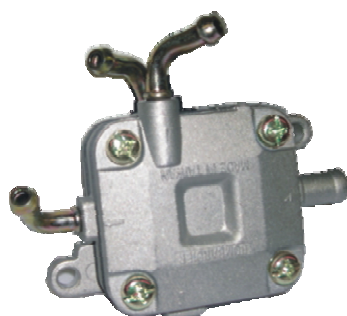

Dual - Hi Volume - Square - Flush
BRP 403-9012-00
598-1883



Dual - Round - Flush
DF52-73



Triple - Round - Flush
DF52-92



Dual - Pentagon - Flush
DF62-702



FUEL PUMP REBUILD KITS

Wafer Style Fuel Pump Rebuild Kits for DF44-211 Retangular Fuel Pump

- A/C - 0636-272 / Bombardier - 403.8003.00 / Polaris - 3083115, 3083116, 3083117

Polymer pump material	SPI	598-1876
Polymer pump material	Winderosa 451449	598-1875

Round Single Style Fuel Pump Rebuild Kits for all OE Mikuni Single Outlet

Teflon pump material	Winderosa 451448	598-1873
Teflon pump material	SPI	598-1874

Round Double and Triple Style Fuel Pump Rebuild Kits for Mikuni DF-52 Double or Triple Fuel Pumps

Polymer pump material	SPI	598-1870
Teflon Pump Material	Mikuni MK-DF52	598-1878MK
Teflon Pump Material	Winderosa 451453	598-1879
Teflon Pump Material	SPI	598-1878

Rectangular Style Fuel Pump Rebuild Kits

Fits '74-78 Ski-Doo	Winderosa 462150	598-1866
---------------------	------------------	----------

Square Style Fuel Pump Rebuild Kits for Mikuni DF52-136 Fuel Pumps

- A/C 3636-640

Polymer pump material	Winderosa 451454	598-1871
Polymer pump material	SPI	598-1872

Pentagon Style Fuel Pump Rebuild Kits for Mikuni DF62-702 Fuel Pump

- Polaris 98-00 XCR 600/700/800, most 96-01 Domestic Twins
- A/C 87-00 ZRT 800 Thundercats and Mountincats

Polymer pump material	Winderosa 451457	598-1880
-----------------------	------------------	----------

Dual High Volume Square Fuel Pump Rebuild Kit

07-182

- Fits 598-1883 OEM 403-9012-00
- Ski Doo 1996 Mach 1 / 1997 Formula 583 / 1996 Formula SS, STX, STX LT / 1996-1997 Formula Z, MX 583, MX 670 / 1998-1999 Summit X 670 / 1999 MZX 670 HO, MZX 670 HO TH

Square Fuel Pump Rebuild Kit for Yamaha Rhino Fuel Pump

- Yamaha OEM 8FA-13910-00

Mikuni MK-DF52-531	598-0531
SPI	07-184



07-182



07-184



598-1866



598-1871

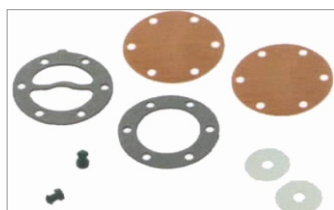

598-1873

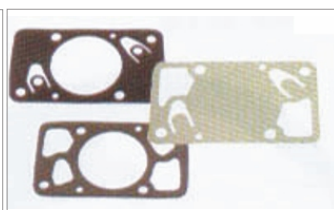

598-1875



598-1879



598-1880

KEIHIN FUEL PUMP REBUILD KIT



Triangular Style Fuel Pump Rebuild Kit for Keihin

Fits Keihin fuel pump found on Yamaha (OE 8A5-24410-00-00, 8A5-24410-01-00, 8A5-24410-02-00, 8K4-24410-00-00)

- Made by Winderosa Part #451420

Polymer pump material

598-1877

CARBURETOR REBUILD KITS - PWC

Mikuni BN Round Pump Rebuild Kit

- Carburetor kit for diaphragm pump-type carburetors found on Personal Watercrafts.
- For BN34, BN38 & BN44 Round Pump Carburetors found on early Yamaha, Kawasaki Personal Watercrafts with round style pump chamber.

Made by Mikuni MK-BN38/44

Made by Winderosa Part#462140 598-1400

Mikuni BN Square Pump SPR Rebuild Kit

- Fits Mikuni Super BN carburetors 34 mm, 38 mm, 44 mm, and 46 mm

Made by Mikuni MK-BN38/44 SPR

Made by Winderosa Part# 451460 598-1460

Mikuni Super BNi Rebuild Kit

- Fits Mikuni Super BNi carburetors

Made by Mikuni MK-BN46i

Made by Winderosa Part# 451469 598-1469

CARBURETOR REBUILD KITS - ATV

ATV Carburetor Repair Kits

Complete kits to rebuild O.E. carburetors. Each kit contains all necessary gaskets, o-rings, float valve and jets.

* repair kit designed for 2 carburetors

Model	Year	TCI #
HONDA		
TRX 90	99-08	598-3047
TRX 250X	87-88 / 91-92	598-3020
TRX 300EX	93-08	598-3038
TRX 400FA / TRX 400FGA	04-07	598-3045
TRX 450ER / TRX 450R	06-09	598-3050
TRX 450R	04-05	598-3049
TRX 500FA / TRX 500FGA	01-04	598-3043
TRX 650FA / TRX 650FGA	03-05	598-3046
POLARIS		
Trail Blazer	96-00	598-3405
Xplorer 4x4	2000	598-3405
SUZUKI		
LT 250R	88-92	598-3218

Model	Year	TCI #
KAWASAKI		
KVF 360	03-09	598-3112
KLF 400	96-99	598-3108
KSF 400	03-06	598-3221
KVF 400	99-02	598-3110
KVF 650	02-09	598-3113 *
KSV 700	04-09	598-3116 *
KVF 700	04-06	598-3113 *
YAMAHA		
YFM 350R	04-08	598-3322
YFM 350 / 4WD	04-09	598-3321
YFZ 350	88-06	598-3308
Big Bear 400	00-12	598-3312



KEIHIN DIAPHRAGM AND GASKET SETS

Keihin HD Style

598-2182

- Made by SPI
- For Keihin carburetor that resemble a Tillotson HD Carburetor
- Kimpex/SPI 07-218-02, Winderosa 451459



Keihin CDKII

598-2183

- Made by Winderosa Part #451468
- Fits wide range of Keihin 38 - 44 mm carburetors.
- Kit includes Viton tipped in-line needle.

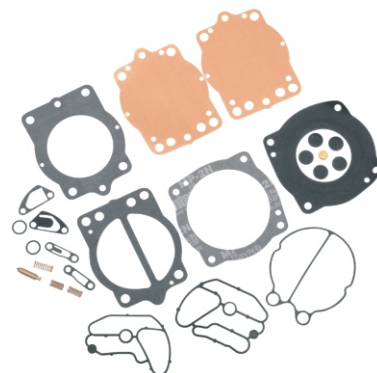

TILLOTSON CARBURETOR REBUILD KITS

Tillotson HL Rebuild Kit

Made by Winderosa Part #451464

598-2220

- Fits most HL Tillotson



Tillotson HR Rebuild Kit

Made by Winderosa Part #451465

598-2231

Made by SPI

598-2230

- Marvel, Schebler / Tillotson RK-1HR
- A complete repair kit, including diaphragm and gaskets, needle and seat, high and low speed needles



Tillotson HD Rebuild Kit

Made by Winderosa Part #451466

598-2240

Made by SPI Part

598-2241

- Universal repair kit.
- Replacement of Tillotson repair kits RK-1HL, RK-1HR, RK-1HD.
- Fits all Tillotson HD carburetors.

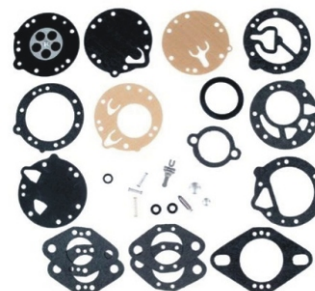

TILLOTSON DIAPHRAGM AND GASKET SETS



Tillotson HR Carburetors

Made by Winderosa Part #451401 598-2151

Made by SPI 598-2150

- 9 piece kit



Tillotson HD Carburetors (DG-1HD)

Made by Winderosa Part #451402 598-2160

Made by SPI 598-2161

- 6 piece kit



Metering Diaphragm For Tillotson HD Carb

Made by Winderosa Part #451403 598-2640

TILLOTSON REPLACEMENT PARTS

TILLOTSON CARBURETOR NEEDLE AND SEATS

Needle and Seat for Tillotson HL & HR Carbs

- Marvel, Schebler / Tillotson 233-672
- Tillotson 014602
- Bombardier 404.0159.00

598-2290



Needle and Seat for Tillotson HD Carbs

- Marvel, Schebler/Tillotson 233-674
- Tillotson 014683
- Bombardier 404.0229.00

598-2300

Needle and Seat for Tillotson HD Carbs (Fork Type)

- Marvel, Schebler/Tillotson 233-682
- Tillotson 015596

598-2301

TILLOTSON CARBURETOR WELCH PLUGS

Welch Plugs Tillotson HR & HL

- Marvel, Schebler/Tillotson 179-55
- Tillotson 02531
- Bombardier 404.0010.00
- Small 0.380"

07-239

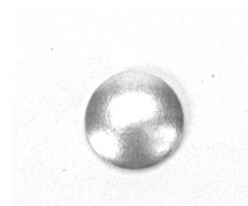

Welch Plugs Tillotson HD

- Marvel, Schebler/Tillotson 0179-57
- Tillotson 04326
- Bombardier 404.0011.00
- Large 0.440"

07-240



WALBRO DIAPHRAGM AND GASKET SETS

Walbro WD Carburetor

Made by Winderosa Part #451410

598-2170

Made by SPI

598-2171

- High performance diaphragm & gasket kit for Walbro Series WD, WDA, WDB, WR, WRA, WRC
- Walbro 92-534



Walbro Float Type Carburetor

Made by Winderosa Part #451447

598-2180

- Series WF
- Diaphragm and gasket kit
- Walbro 92-548

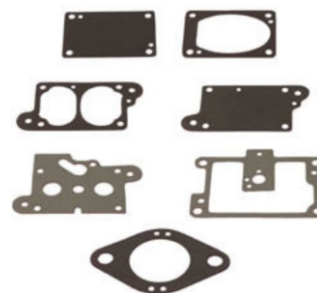

INTAKE GASKETS

Tillotson HR, Walbro WR

598-2480

and Mikuni HR Carburetors

- Bombardier - 404.0039.00
- Marvel, Schebler/Tillotson 16B-241
- Tillotson 014319
- Walbro 92-151
- 0.8 mm
- Non asbestos



Carburetor Spacer Blocks

598-2497

- Tillotson HD and Walbro WD
- 1/4" thick
- 75 mm center to center



Spring Fuel Pump Leaf

598-2194

- Series: WD - WR
- Walbro 98-215

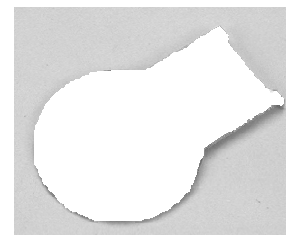

AIR INTAKE TUBES

Universal Air Breather Assembly for Tillotson and Walbro Snow Carburetors

Sturdy plastic body with a removable foam filter for easy cleaning. A second plastic screen is attached under the foam filter that allows for use without the filter, preventing foreign objects from entering the carburetor.

DESCRIPTION	PART #
Tillotson HD/Walbro WD Carburetor	598-9902
Tillotson HR/Walbro WR Carburetor	598-9903



Universal Air Intake Tubes for Mikuni VM Models

Aluminum spigot carburetor, chrome finish body with screen cover prevents foreign objects from entering the carburetor.

DESCRIPTION	SIZE	PART #
Mikuni VM30 SB	1.97" dia x 2.5" high	598-9801
Mikuni VM30-34	2.275" dia x 2.5" high	598-9802
Mikuni VM30-34	2.275" dia x 2" high	598-9900
Mikuni VM36-38	2.475" dia x 2" high	598-9901



IN-LINE FUEL FILTER HOSE ASSEMBLY

Polaris Fuel Filter Hose Assembly 760-2451 (07-246-05)

- Fits Most Polaris 700 and 900 Fuel Injected models from 2005 to 2006
- Polaris OEM 2520377



Polaris Fuel Filter Hose Assembly 760-2452 (07-246-36)

- Fits most Polaris 600, 700 and 800 models from 2008 to 2011
- Polaris OEM 2520771



Polaris Fuel Filter Hose Assembly 760-2453 (07-247-27)

- Fits most Polaris 600 and 800 models from 2012 +
- Polaris OEM 2521119, 2521095, 2521192



FUEL FILTERS

Screw-On Carb Fuel Filter 760-2460

- For Tillotson HD & HR carbs screw-in type
- Bombardier
- Fram G 30
- Purolator GF-23



Walbro Style See-Through Filter 760-2450

- Improved see-through filter with a larger fuel flow capacity of 15 gallons per minute.
- Fits 3/16" and 1/4" fuel line.





FUEL FILTERS

In-Line Fuel Filter (7/32")

760-2463

- Universal
- Replaces Fram G-1



In-Line Fuel Filter (1/4")

760-2464

- Universal
- Replaces Fram G-2



Small

760-25

- Capacity - 11-12 gallons fuel flow
- Nylon screen traps all dirt particles



Large

760-26

- Jumbo fuel filter
- Nylon screen has self-cleaning action
- Fits both 7/32" and 1/4" I.D. fuel line



Inside Fuel Line Filter (1/4")

760-27

- Red nylon in-line filter
- Fits inside fuel line



Filters

- Made of high impact nylon for durability
- Eliminates dirt and other contaminants
- Resistant to gasoline, gasohol and diesel
- Ultrasonically welded for no-leak construction

Visu Filter

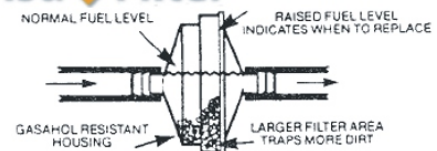

Flat - Stainless Steel

760-401

- *Stainless steel* 75 micron filter element
- Overall Diameter: 1.3" (33mm); Inlet Diameter: 5/16" (8mm)
- Length between hoses: .95" (24mm); Length: 1.75" (44mm)
- Fits Fuel Line ID: 3/16"-1/4" (47 -63mm)



Small Cone - Bronze

760-701

- Sintered Bronze 75 micron filter element
- Overall Diameter: .87" (22mm); Inlet Diameter: 5/16" (75mm)
- Length between hoses: 1" (26mm); Length: 2" (52mm)
- Fits Fuel Line ID: 3/16"-1/4" (47 -63mm)



Small Cone - screened

760-704

- screened at 75 micron filter element
- Overall Diameter: 1.8" (20mm); Inlet Diameter: 5/16" (75mm)
- Length between hoses: 1.25" (30mm); Length: 2" (52mm)
- Fits Fuel Line ID: 3/16"-1/4" (47 -63mm)



FUEL FILTERS

Emgo Fuel Filter

E14-34480 1/4" \$36.95-J/10 per card or E99-34480 each
 E14-34481 3/8" \$36.95-J/10 per card

- In-Line fuel filter for 5/16" fuel lines
- Nylon casing with paper filter element.
- Replaces Honda OEM # 16900-M68-003 / 16900-371-004



Model	Year	TCl#
HONDA		
CH250	89-90	E14-34480
CN250 Helix	86-01	E14-34480
VF500C V35 Magna/Interceptor	84-86	E14-34480
VF700C V45 Magna	82-86	E14-34480
VF700F Interceptor	84-85	E14-34480
VT700C Shadow	83-85	E14-34480
VF750C V45 Magna	82-86	E14-34480
VT750C Shadow	83-85	E14-34480

Model	Year	TCl#
HONDA		
GL 1000	76-79	E14-34480
VF 1000F Interceptor	84	E14-34480
GL1100	80-83	E14-34480
VF1100C V65 Magna	83-86	E14-34480
VF1100S V65 Sabre	84-85	E14-34480
GL 1200	84-87	E14-34480
GL 1200 A/1/SE Goldwing	88-00	E14-34481



GAS TANK FILTERS

Gas Tank Filter (7/32" & 1/4")

760-2411

- KMP #07-241-01
- Yamaha 8H5-24560-00-00
- 1971-1999 All Models



In-Tank Fuel Filter w/check valve

760-2410

- Built in check valve to prevent fuel from flowing back into the tank
- Fits all 7/32" and 1/4" fuel line
- Replaces Polaris 7052301 and Bombardier 414.8657.00



760-2410/760-2409

In-Tank Fuel Filter no check valve

760-2409

- Fits 3/8" fuel line
- Replaces Polaris 7052081
- No check valve



Gas Tank (In Tank) Filter

760-7002

- Brass with steel mesh screen

Primer Inlet

VM34/181

- Drill hole on carburetor flange to install.

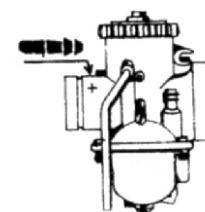



OIL INJECTOR FILTER

In-Line Oil Injection Filter

760-7070

- Hose diameter 5/16"
- Fits Polaris Snowmobile OEM #2670071/2530009 (All oil injection system models from '74-07 except U.S. Made Twins)
- Fits many Polaris ATV 85-00
- Bombardier OEM #414-5365-00



Oil Injection Filter

760-7020

- Fits 3/16" Fuel Line
- 1/4" valves at both ends
- Replaces Yamaha OEM #859-13410-00



Oil Injection Filter

760-2462

- 5/16" Fuel Line
- 5/16 and 1/4" ends
- Fits many '74-05 oil Injection equipped snowmobiles
- Fits Polaris and Yamaha US made motors



Yamaha OEM 8G8-13410-00 / J10-13410-00 - CF 300 '86-90, CS 340 '89-00, EC '79-80/82EC 340 '81-88, ET 300 '79-84, ET 340 '78-88, ET 400 '89-90, ET 410 '92-01, EX 570 '87-93, GP '74-78, GPX '74-75, GS '75-78, MM800, 1997, PR '76-77, SL 1974, SM 1974, SR 540 '80-91, SRX 440 '80-81, SS 440 '80-85, SRV 540 '84-91, STX '76-77, TL '74-75, TW 1974, VK 540 '88-05, VMX 540 '83-87, VX 500/600 '94-96, VX 750 '92-94, VX 800 '95-97, XL540 '85-90

PRIMERS AND PRIMER KITS

Push Button Kit

760-2340

- Complete with filtered T fitting & primer hose.
- Dash mount installation.



Plunger Primer only

760-2332

- OE quality
- Made in the USA



Plunger Primer Kit

760-2332K

- 1/8" hose
- T-fitting fuel valve
- Dash mount plunger



Primer Bulbs

- Rubber Bulb in-line type primer complete with built-in check valves.
- Can be installed at any point along fuel line.
- Universal

7/32"

760-2370

1/4"

760-2380



FUEL TANK FITTINGS

760-2761



760-2760



Fuel Tank Fitting (1/2")

760-2760

- Aluminum press fitting
- Can be added to any metal tank by drilling 1/2" insert fitting, and tighten.

Rubber Grommet

760-2761

FUEL LINE T'S



760-2770

Fits 7/32" & 1/4" I.D.
Fuel Line



760-2780

Fits 1/8" I.D.
Fuel Line



760-2790

Combo for 7/32" or 1/4" I.D. Fuel Line
with 1/8" I.D. Primer Hose

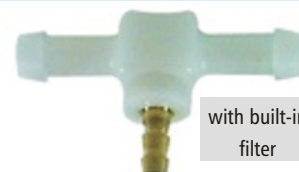

with built-in
filter

760-2791

Combo for 7/32" or 1/4" I.D. Fuel Line
with 1/8" I.D. Primer Hose

FUEL VALVES



760-11356

2-Way
Fits 3/16", 7/32, 1/4" I.D. Fuel Line



760-11118

SPI 2-way (90°)
Fits 1/4" I.D. Fuel Line

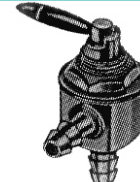

760-12431

2-way (90°)
Fits 5/16" I.D. Fuel Line



2-way (180°)

760-2810 for 1/4" Fuel Line
760-2811 for 5/16" Fuel Line
760-2810 for 3/8" Fuel Line



722-8038

2-way (180°)
For 3/16" I.D. Fuel Line

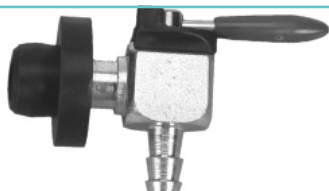

760-11032

2-way (90°)

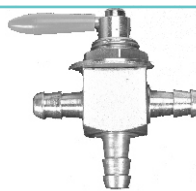

760-11079

3-way



FUEL LINE

Blue Transparent Fuel Line

- Clear Blue 100 PU .
- sold by the roll
- Hardnes 85A, cold resistant to -50c
- Made in Taiwan.

1/8" x 25 feet	760-0105
3/16" x 50 feet	760-0205
1/4" x 50 feet	760-0305
5/16" x 50 feet	760-0405



760-0205

Emgo Black Rubber Fuel & Oil Line

- Available in Black Reinforced or Plain Rubber.
- Neoprene outer cover resists grease and oil.
- Sold in 25 foot rolls.

1/16" Reinforced Black Rubber	E14-03701
-------------------------------	-----------



E14-03701

Carburetor Accessory Hose Kit

The carburetor accessory hose kit replaces your vent hoses with quality silicone hose for a customized factory look.

- Three different size of hoses 12ft of 5/32, 8ft of 3/16, 4ft of 1/4
- Silicone is resistant to heat, UV rays, gas and oil, providing a long lasting product
- Replaces stock or worn carburetor vent hoses

COLOUR	PART #
Silver	760-90305



FUEL LINE CLIPS

Fuel Line Clips

APPLICATION	I.D.	PART #
Wire Style for 7/32" hose	8.5 mm	760-2850
Band Style for 1/4" hose	8.5 mm	760-2900
Band Style for 3/16" hose	9.8 mm	760-2901
Band Style for 5/16" hose	11.6 mm	760-2902
Wire Style for 1/4" hose		760-2903
Wire Style for 5/16" hose		760-2904



Band Style



Wire Style